

GOODWE



INSTALLATION MANUAL

GOODWE PVBM

UP TO A SUSTAINABLE FUTURE

M10 GALAXY PLUS

BMT-G4/088A

CONTENT

1

DESCRIPTION OF THE
MAIN STRUCTURE
OF GALAXY PLUS
PRODUCTS

P3**2**

INSTALLATION
MATERIALS LIST

P4**3**

INSTALLATION TOOLS
LIST

P6**4**

PRE-INSTALLATION
INSPECTION WORK
OF GALAXY PLUS
PRODUCTS

P7**5**

INSTALLATION WORK
OF GALAXY PLUS
PRODUCTS

P9**6**

ELECTRICAL
INSTALLATION

P28**7**

ELECTRICAL
CONSTRUCTION
PROCESS

P32**8**

OPERATION AND
MAINTENANCE

P34**9**

CAUTIONS

P35

1

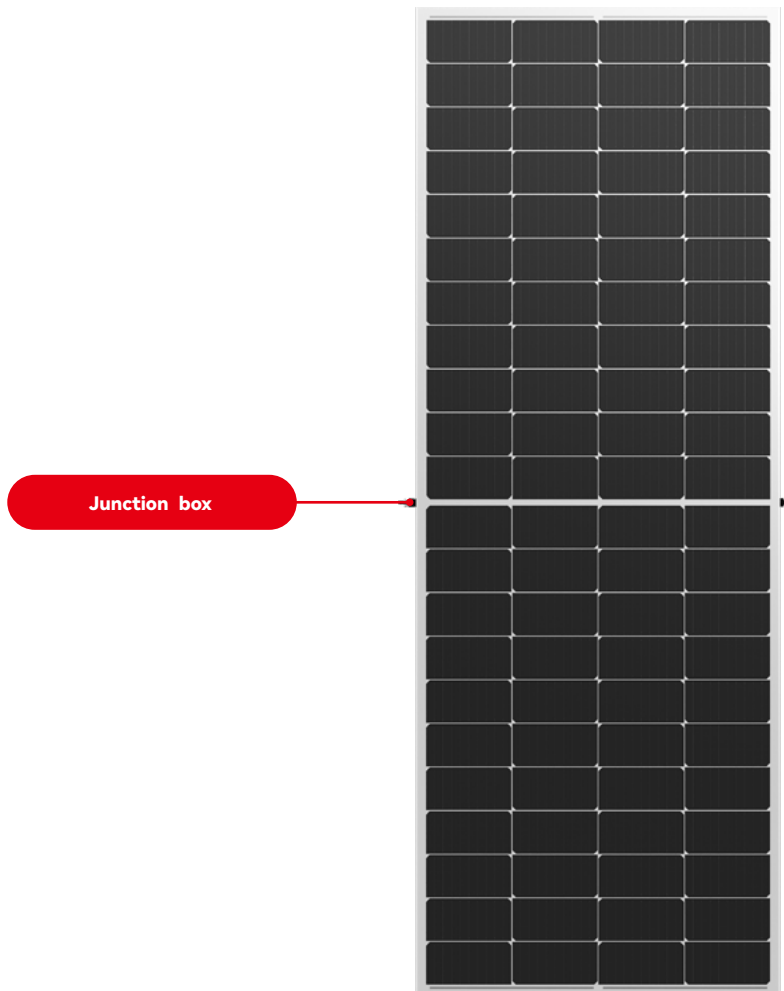
DESCRIPTION OF THE MAIN STRUCTURE OF
GALAXY PLUS

FRONT SIDE OF GALAXY PLUS PRODUCT

Installation Altitude <2000m

Fire Protection Level: CLASS C (According to the corresponding certification standard IEC 61730-2-MST23)

Protection Level: Level II

Maximum static load: front 2400Pa; back 2400Pa

2

INSTALLATION MATERIALS LIST

2.1 CLAMP KIT

PS: Select one of the following clamp kits according to the roof type. Provided by GoodWe.
 Angle ridge type clamp kit (Customized Standard)



Standing seam type clamp kit (Customized Standard)



Low standing seam type clamp kit (Customized Standard)



Clamp kit (Overseas) (Customized Standard)

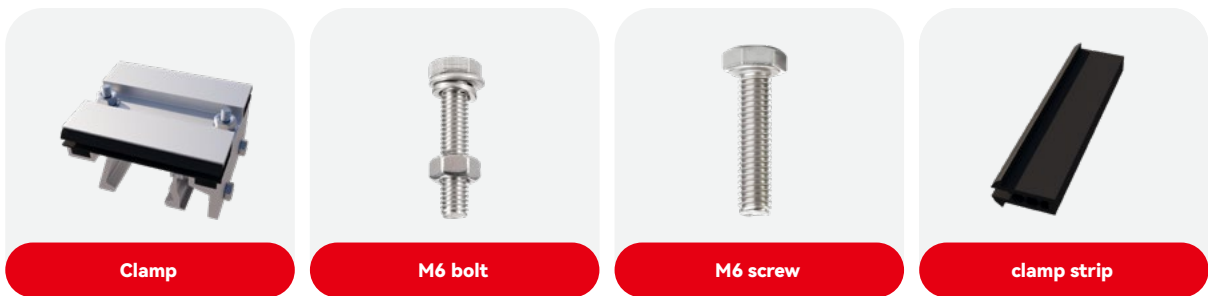

2.2 ADHESIVE KIT

PS: Select based on the installation method. Not provided by GoodWe, can be purchased locally.



3

INSTALLATION TOOLS LIST

3.1 CONSTRUCTION TOOLS LIST



Tape Measure



Chalk Line



Utility Knife



Electric Impact Wrench



Adhesive gun

PS: This list only indicates the main tools required for the installation of Galaxy Plus Products' structural system, excluding the tools used for the installation of the roof support section and the electrical section.

For the tools of release and installation of roof brackets, you can refer to the preparation of building works.

3.2 ELECTRICAL TOOLS LIST



Needle Nose Plier



Wire Cutter



Photovoltaic special crimping pliers



Wire stripping plier



Joint wrench

4

PRE-INSTALLATION INSPECTION WORK OF GALAXY PLUS PRODUCTS

**WARNING**

- Please use insulated tools to reduce the risk of electric shock.
- Please adopt appropriate protective measures (non-slip gloves, work clothes, etc.) to avoid direct contact with 30V DC or higher, and avoid direct contact with sharp edges during installation
- Please do not wear metal ornaments during installation to avoid poking through the Galaxy Plus products and causing electric shock hazards.
- DO NOT install the product in rainy weather or strong wind.
- DO NOT allow children or unauthorized personnel to approach the installation area or the storage area of Galaxy Plus products.
- During installation or wiring of Galaxy Plus products, if the circuit breaker and overcurrent protection circuit breaker cannot be turned on or the inverter cannot be turned off, then use an opaque material to cover the array of Galaxy Plus products to stop the power output.
- DO NOT use or install Galaxy Plus products that have been damaged.
- If the surface material is damaged or worn, direct contact with the surface of Galaxy Plus products may result in electric shock.
- DO NOT attempt to repair any part of the Galaxy Plus product.
- The lid of the junction box should be kept closed at all times.
- DO NOT disassemble, modify, or move any part of the Galaxy Plus product.
- DO NOT artificially concentrate light on Galaxy Plus products.
- It is important to note that only one piece of product can be moved in a single operation when installing Galaxy products.

**BE CAREFUL**

- Before installing Galaxy Plus products, the relevant authorities should be contacted to obtain information about the installation site and construction permits, and the requirements for installation and inspection should be observed.
- Check the applicable building codes to ensure that the building and its structure (roof, exterior façade, load bearing, etc.) in which Galaxy Plus products are to be installed have adequate load-bearing capacity.
- Ensure that Galaxy Plus products are installed on a fireproof roof.
- Galaxy Plus products are compliant with Safety Class II. These Galaxy Plus products can be used in systems where the public is likely to be exposed to voltages greater than 50V or power greater than 240W.
- The installation surface should be flat and free of pits or bumps.

- Galaxy Plus products must not be installed near flames or combustible objects.
- Galaxy Plus products must not be immersed in water (pure or salt water), installed in environments that are permanently wet (pure or salt water) (e.g. fountains, waves, etc.) or in locations where water is likely to accumulate (e.g. potholes, drainage inlets, etc.).
- There is a risk of corrosion if Galaxy Plus products are placed in salt spray (i.e., marine environments) or environments containing sulfur (i.e., sulfur-containing sources, volcanoes, etc.).
- Ensure that Galaxy Plus products meet the overall technical requirements of the system.
- Ensure that other system components do not cause damaging mechanical or electrical performance effects on Galaxy Plus products.
- It is allowed to connect Galaxy Plus products in series to increase the voltage or in parallel to increase the current. When connected in series, the positive terminal of the Galaxy Plus product is connected to the next negative terminal. When connected in parallel, the positive terminal of the Galaxy Plus product is connected to the positive terminal of the next Galaxy Plus product.
- To avoid (or minimize) the mismatch effect of the array, it is recommended to connect Galaxy Plus products with similar electrical properties on the same string.
- To reduce the risk of indirect lightning strikes, the system should be designed to avoid the creation of loops.
- Galaxy Plus products should be securely fastened so that they can withstand all possible loads, including wind and snow loads.
- During the installation process of the Galaxy Lightweight products, it's advisable to minimize repeated moving and handling.
- During the installation of Galaxy products, avoid people gathering as far as possible to prevent the product from being pulled and broken due to excessive local load on the roof.
- During the installation of Galaxy products, attention shall be paid to the protection of the colour steel tile roofing to prevent damage to the waterproofing of the roof caused by the fracture of the colour steel tile.
- If the roof is not rigid enough, it is recommended that the roof be reinforced or a corresponding installation and maintenance channel be added to avoid roofing waterproof damage
- Please ensure that the installation location of Galaxy Plus products is free from shading all year round, as shadows can cause a decrease in the power generation of Galaxy Plus products. Hot spots and long-term heat generation from diodes caused by frequent shading of Galaxy Plus products can affect the service life of Galaxy Plus products.

5

INSTALLATION WORK OF GALAXY PLUS PRODUCTS

5.1 UNPACKING AND STACKING (STORAGE AND UNPACKING)

- To ensure the safety of Galaxy Plus products during transportation, it is better to open the packaging box of Galaxy Plus products after reaching the installation site.
- Check whether the box is damaged before unpacking.
- The worker should wear non-slip gloves beforehand to avoid staining the product with oil or dirt and to protect personnel from accidental injury.
- It is advised that unpackers wear non-slip gloves in advance.
- Galaxy Plus products should be stored in a dry and ventilated environment.
- Galaxy Plus products must be shipped in the boxes provided by GOODWE and should be stored in the original boxes before installation. Please protect the packaging from damage. Follow the recommended unpacking procedure to open Galaxy Plus product packaging. Careful handling is required during unpacking, transportation and storage.
- DO NOT apply excessive loads or twist Galaxy Plus products.
- DO NOT use wires or junction boxes to carry Galaxy Plus products.
- DO NOT stand, climb, walk or jump on Galaxy Plus products.
- DO NOT allow Galaxy Plus products to come in contact with sharp objects; scratches can directly affect the safety of Galaxy Plus products.
- DO NOT place Galaxy Plus products in an environment that is not reliably supported or not fixed.
- Changing the wiring of the bypass diode is prohibited.
- All electrical connectors need to be kept clean and dry.
- Galaxy Plus products are not allowed to be stacked flat and the quantity should not exceed 3 pieces. The junction box shall not be in direct contact with the front side.

5.2 CHECKING

- Please check whether the surface of Galaxy Plus products is damaged, if there is damage or wear on the surface of the products, please do not use the product.
- Please check whether the junction box, connectors and cables are damaged. Please do not use the product if there is damage.
- Do NOT apply adhesives, paint, label or any other product on the surface of Galaxy Plus products.

5.3 ROOF SUBSTRATE REQUIREMENTS

- The base layer application scenario is a colour steel roof.
- The surface of the substrate should be uniform, flat and without sharp bumps or burrs, etc.

- The surface of the substrate must be clean, dry, and free from water accumulation

5.4 CONSTRUCTION REQUIREMENTS

Construction ambient temperature limits:

- -10°C to $+60^{\circ}\text{C}$ for ambient construction
- $>5^{\circ}\text{C}$ for contact adhesives/cleaners etc
- It may be mandatory to take measures to ensure safety when working at ambient temperatures below 5°C as required by relevant national codes.

5.5 CHALK LINE POSITIONING

- Measure the roof and determine the position of Galaxy Plus products according to the design drawings.

5.6 CARRYING

- To avoid damaging the cells, two people are required to lift the four corners of the Galaxy Plus product (avoiding touching the position of the cells) at the same time when carrying it.
- The downward bending distance of Galaxy Plus products should not exceed 300mm. Please carefully position Galaxy into predestined location.
- Galaxy Plus products should be carried upright as much as possible when handled manually. Do not twist the product during transportation and avoid front-facing products.
- Care is required during the handling of Galaxy Plus products to avoid them bumping into the ground or other sharp, hard objects.

5.7 INSTALLATION

Colour Steel Tile Roofing Installation:

- Angle-chip colour steel roofing Square rib and Diamond-shaped rib forming its corrugations. (Figure 1) ;

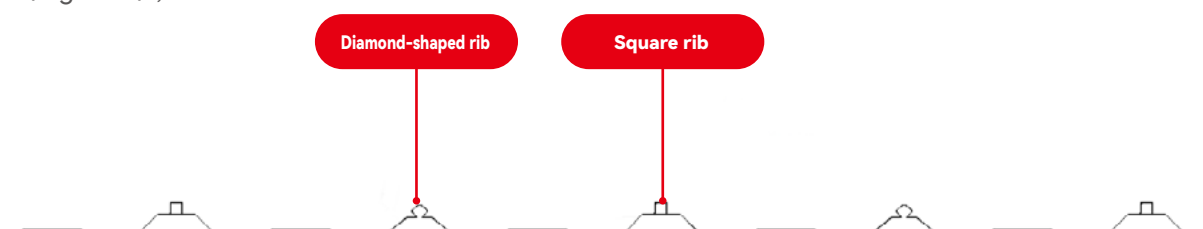

FIGURE 1

- Mark the position of Galaxy and the clamps with snapline, the centre line of each row of the clamp is $816 \pm 2\text{mm}$ apart, note that the snapline is perpendicular to the ridges of the colour steel tile (Figure 2)

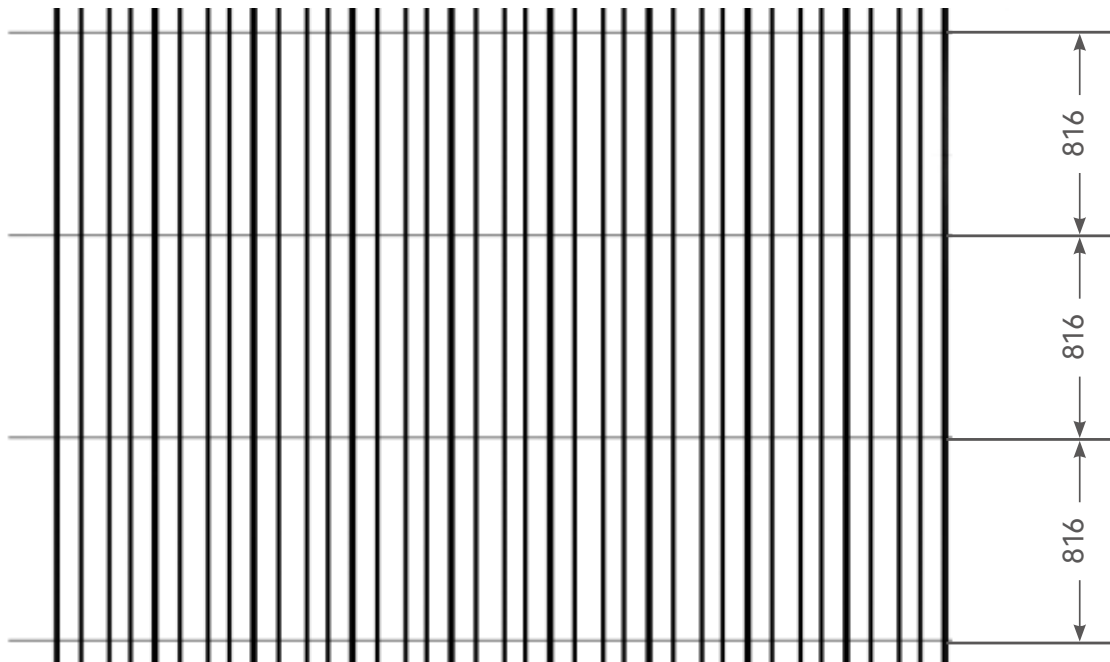

FIGURE 2

- ② Install the clamp on the diamond rib according to the position of the snapline, and use the M6 bolt to lock the clamp for installation (Figure 3) as shown below (Figure 4);

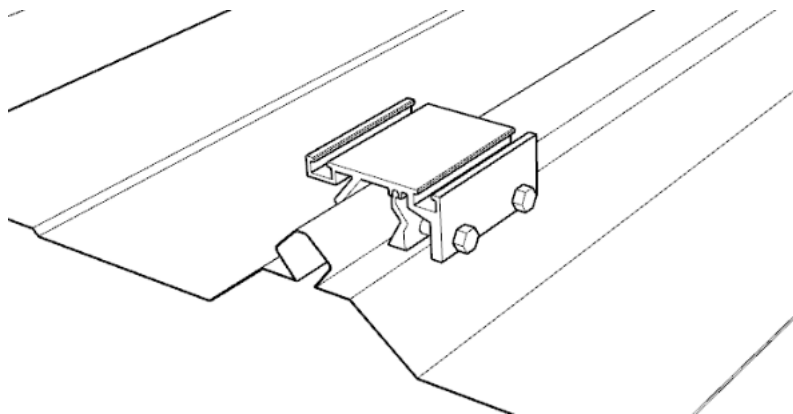

FIGURE 3

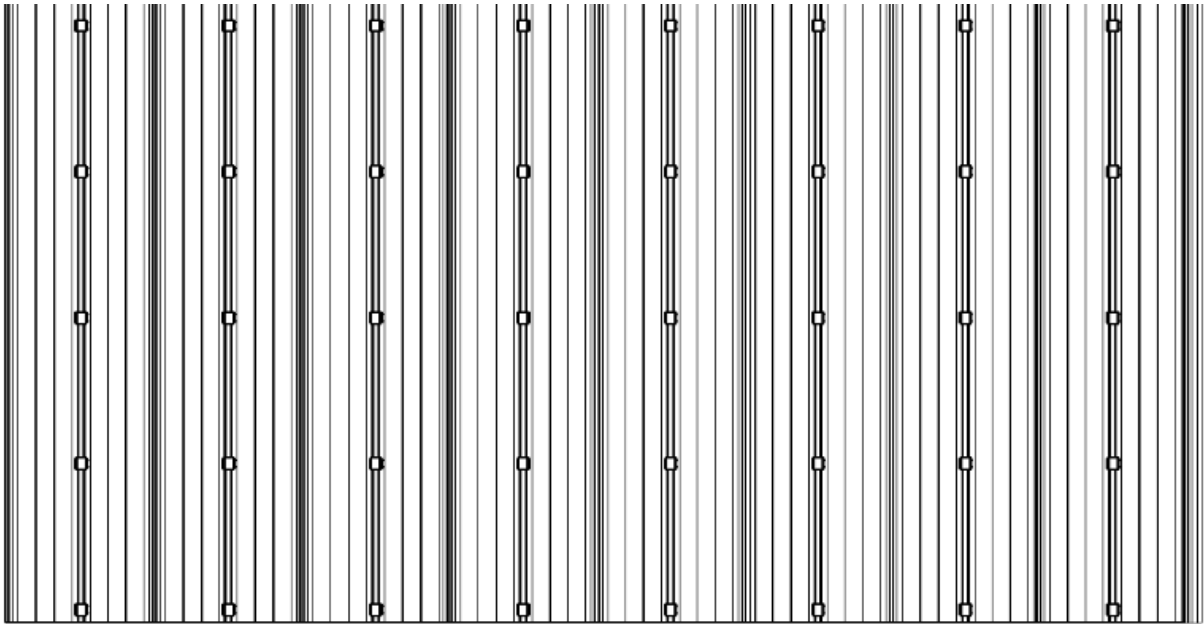
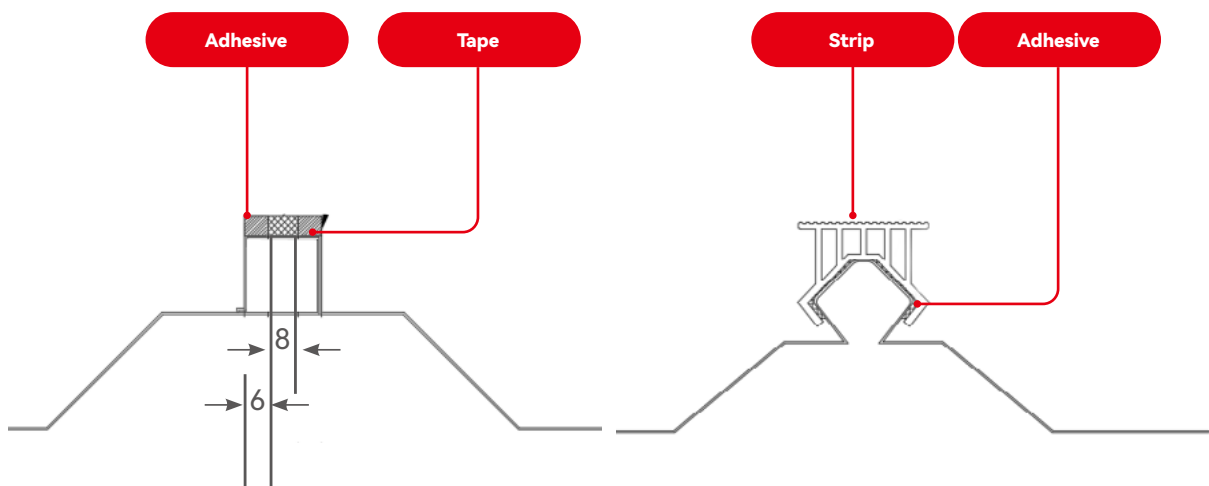

FIGURE 4

- ③ Installing tape and clamp strips, structural adhesive, using tape + adhesive on the square rib to bond the back of the product, the width of the tape is 6mm, the height is 5mm, the surface of the adhesive should be higher than the surface of the tape to ensure that the back of the product can fully contact with the adhesive (Figure 5), the overall length is 150mm, see (Figure 7) for details of the arrangement;
- ④ Use elevating strips on the diamond rib (Figure 6), with one end of the strips pressed against the side of the clamp, with each strip positioned as shown (Figure 7);
- ⑤ Installing in the above installation sequence, the overall installation effect is as follows (Figure 8)
- ⑥ On diamond-shaped ribs, use adhesive to bond strips. One end of the strip is placed against the side of the clamp and the other end of the strip is placed at a distance of 438mm from another strip, with each strip positioned as shown in the diagram (Figure 6)



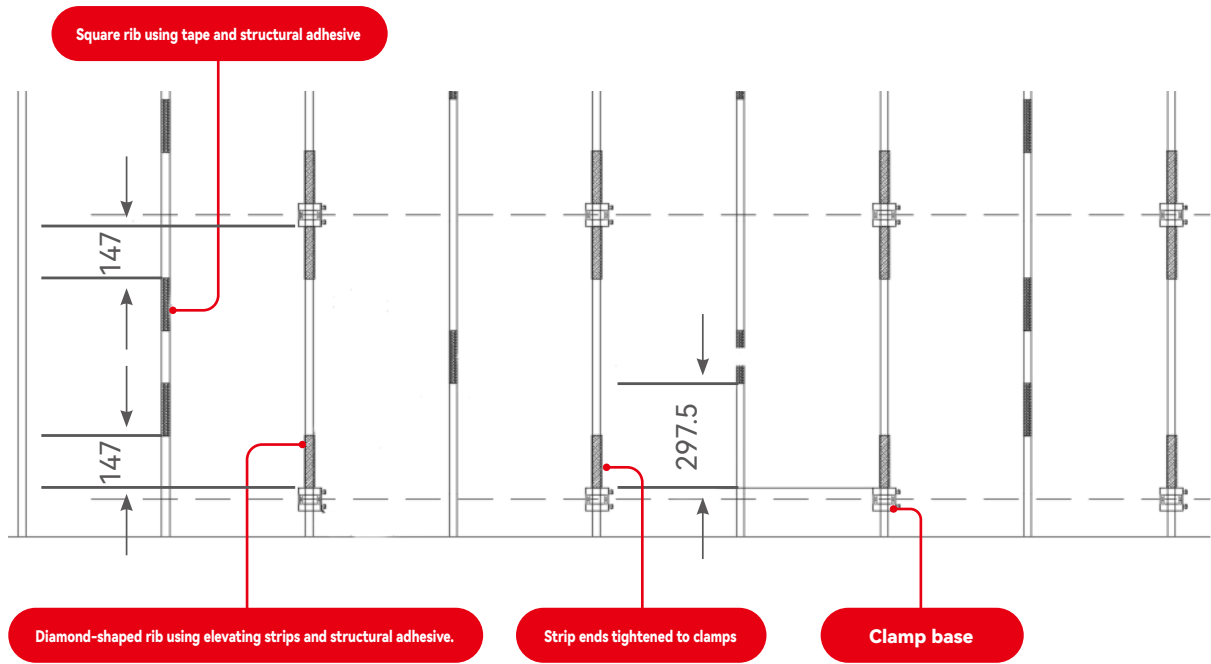

FIGURE 7

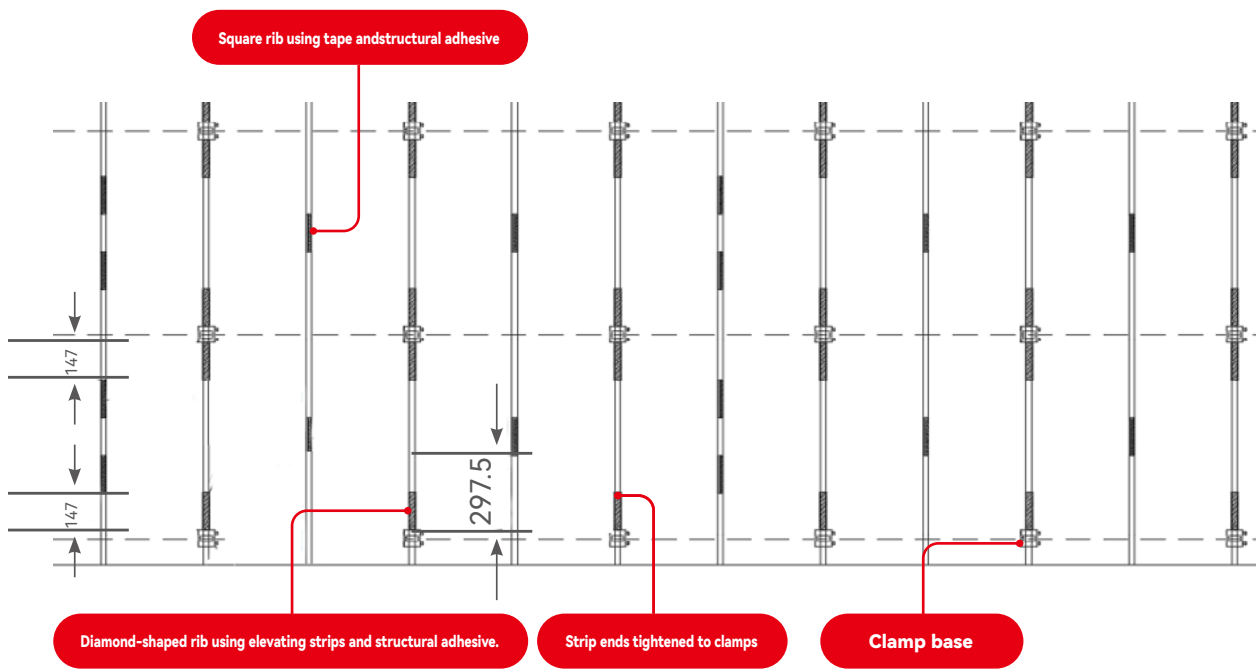

FIGURE 8

⑦ Install the clamp strip onto the product according to the site clamp arrangement (Figure 9), after the installation is completed, put the product onto the clamp and adjust the product position, the edge of the short side of the product should be $12\pm 3\text{mm}$ away from the edge of the square rib (Figure 10), the contact distance between the long side and the clamp should be $\geq 12\text{mm}$ (Figure 11). Also, gently roll and press the front side of the product at the adhesive application area to ensure full bonding of the product's backside with the structural adhesive.

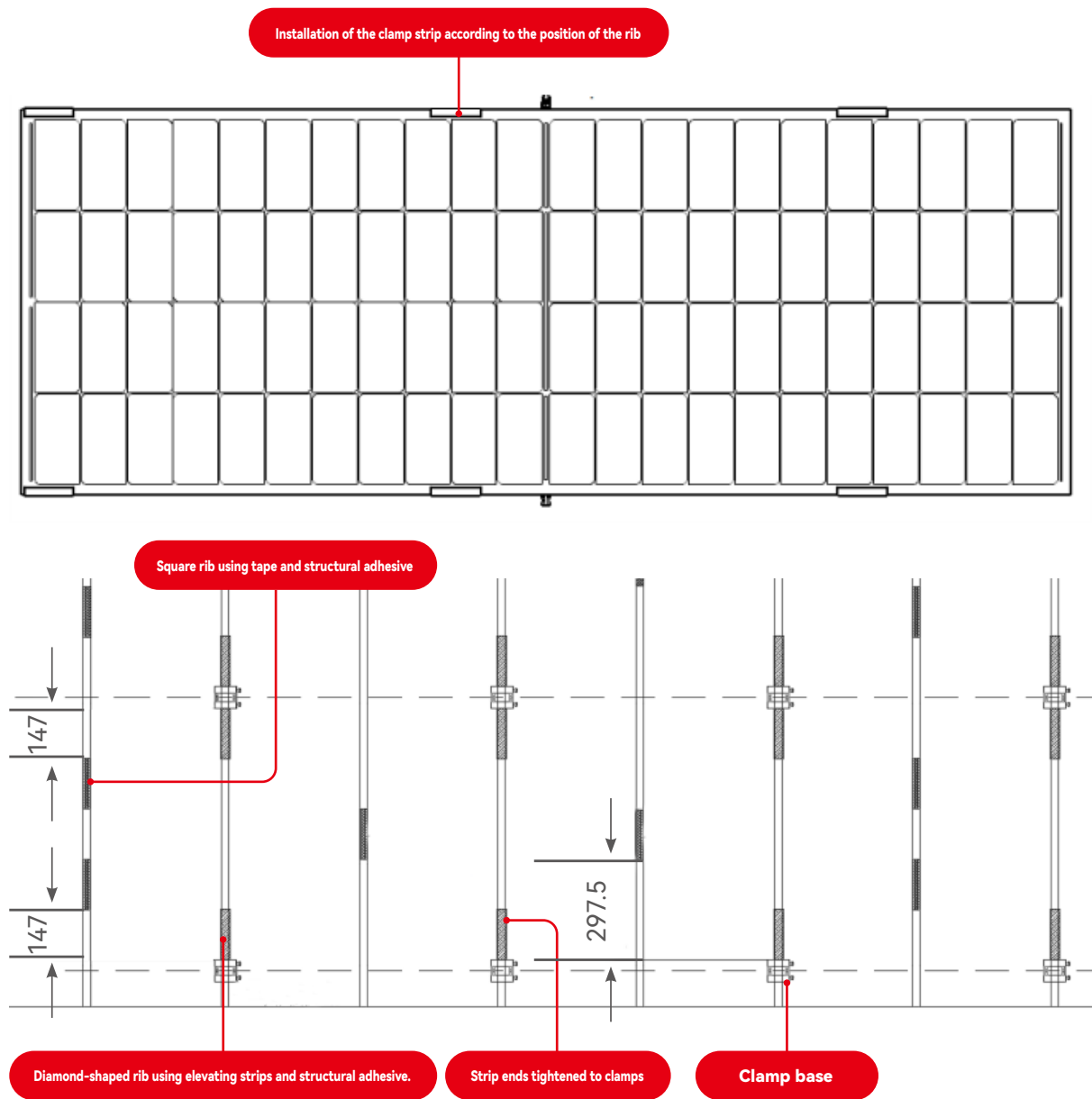

FIGURE 10



FIGURE 11

⑧ Finally, cover the first product with the clamp cover on the first row of clamps and fasten it with washers and nuts (Figure 12) to complete the installation of the first product

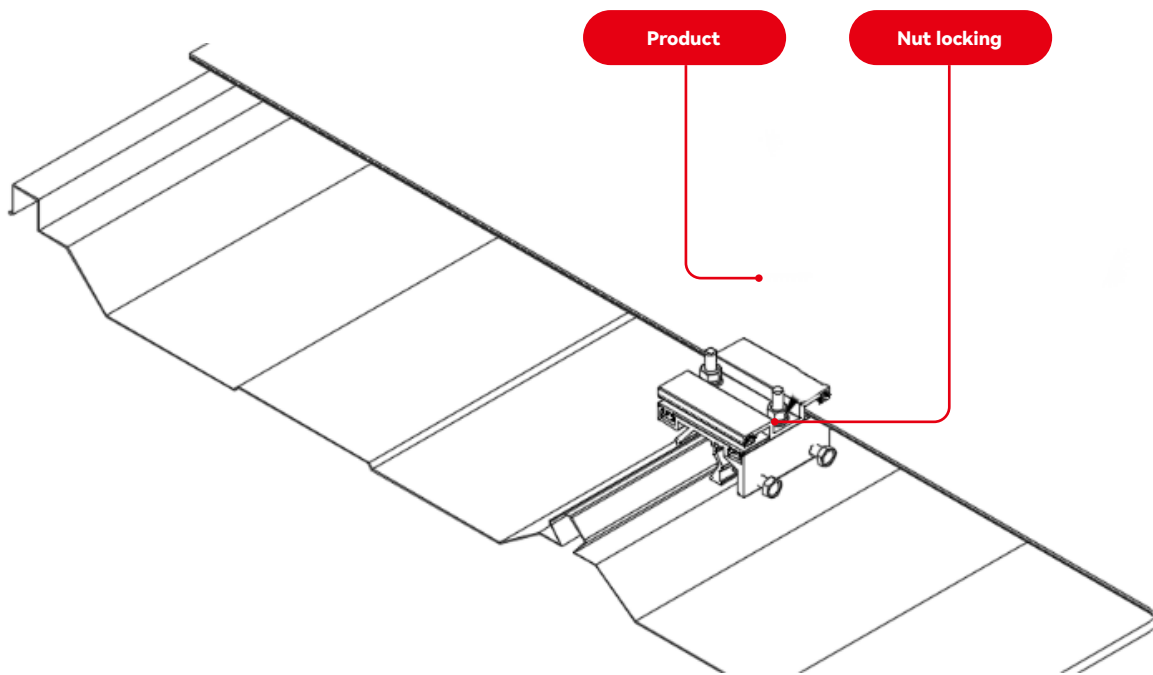

FIGURE 12

⑨ Referring to the installation procedure for the first product, complete the installation of the second product in turn (Figure 13)

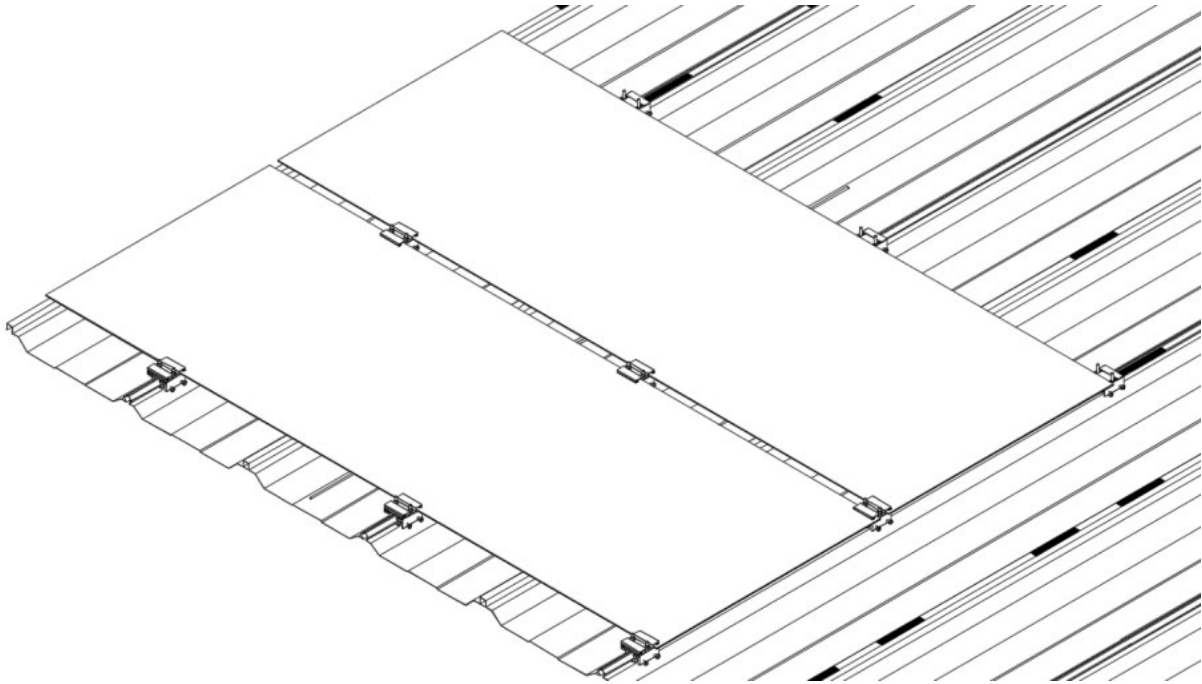

FIGURE 13

⑩ Put the clamp cover on the base of the second horizontal row of clamps and fasten it with washers and nuts (Figure 14)

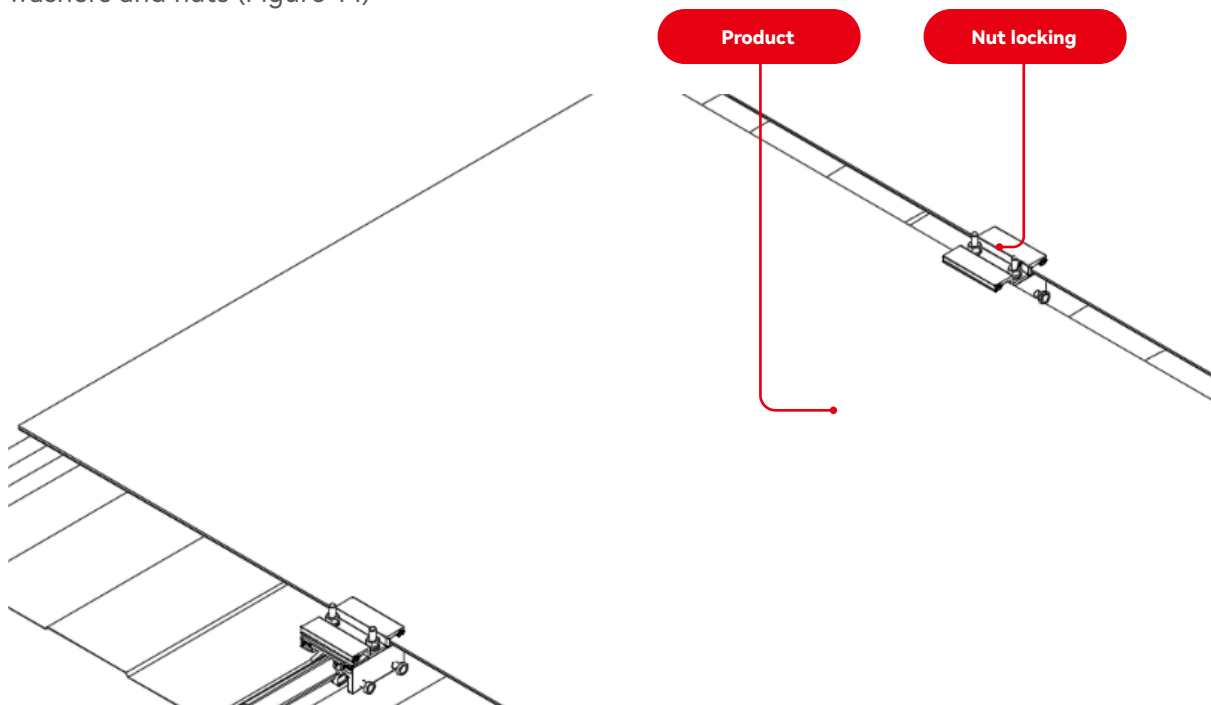

FIGURE 14

⑪ Follow the above installation sequence until all products in the first row have been installed, then tighten the nuts on the last row of clamps to fix the coverboard, so that the first row of products installation is finished (Figure15)

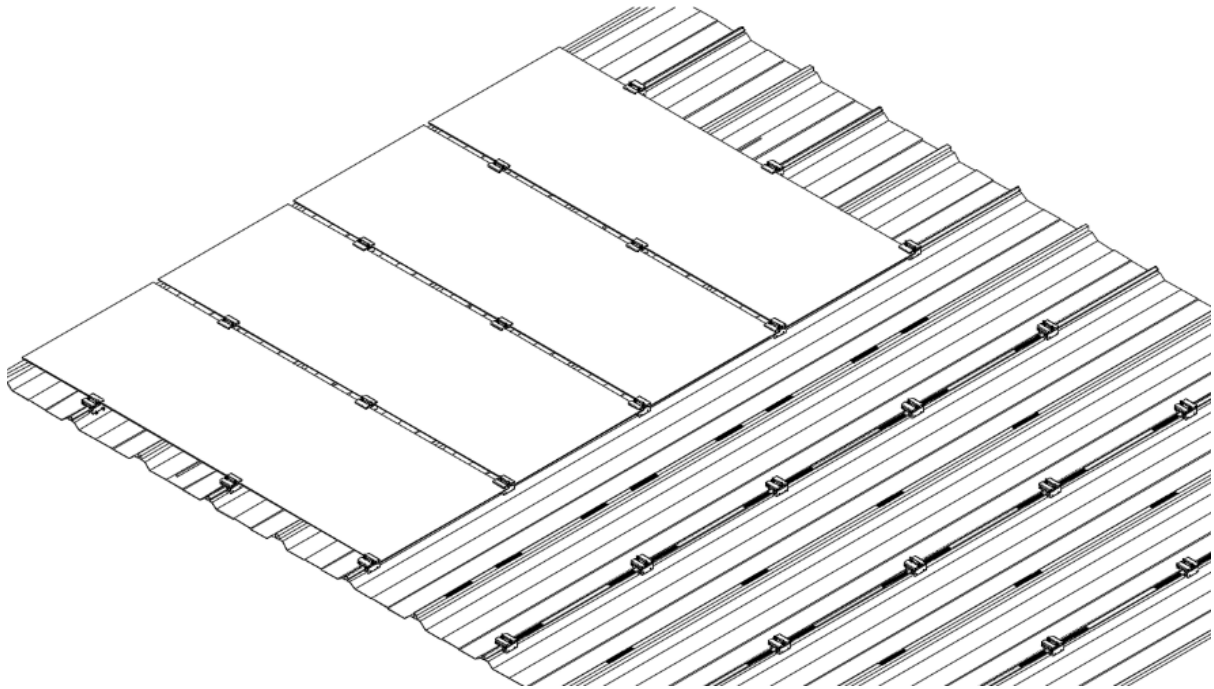

FIGURE 15

⑫ The second row of products is installed with reference to the first row of installation, and then the third and fourth rows are installed in turn until the installation of all products is complete (Figure 16);

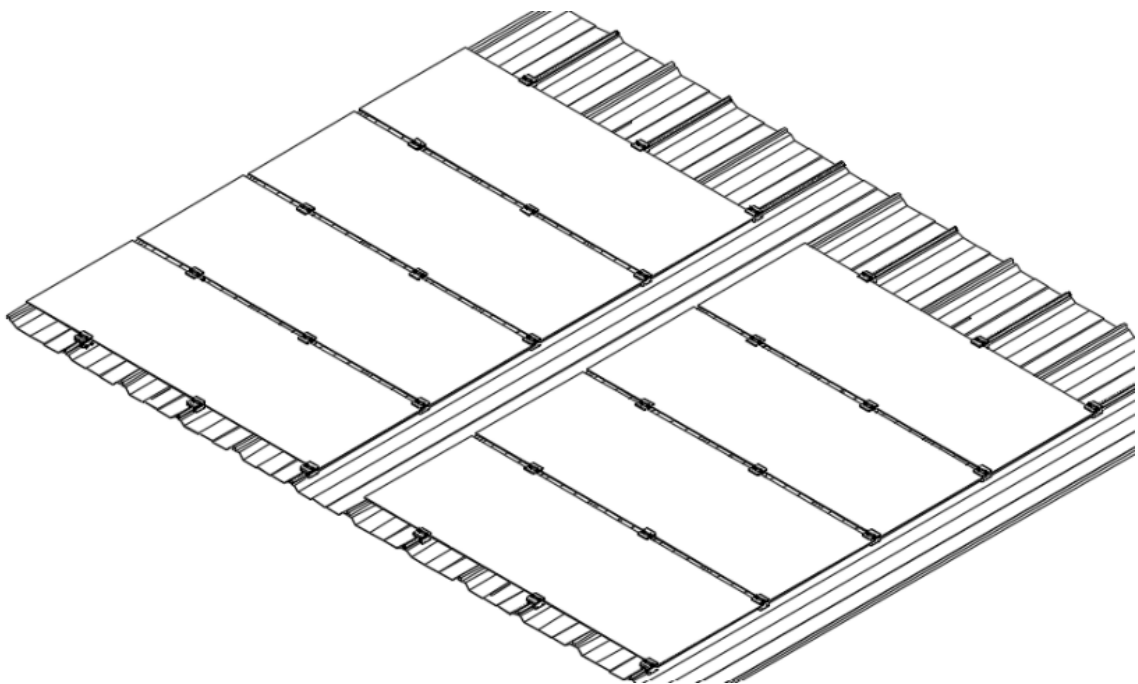

FIGURE 16

Other forms of installation of angle chipped colour steel tile roofing:

Angle-chipped colour steel tile ribs are all diamond-shaped ribs (Figure 17)

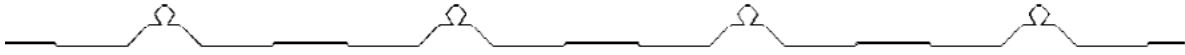

FIGURE 17

① First determine the installation position of the clamp, then carry out the snapline as the installation axis, the centre line of each row of the clamp should be $816 \pm 2\text{mm}$ apart, note that the snapline is at an angle of 90 degrees to the rib of the colour steel tile (Figure 18)

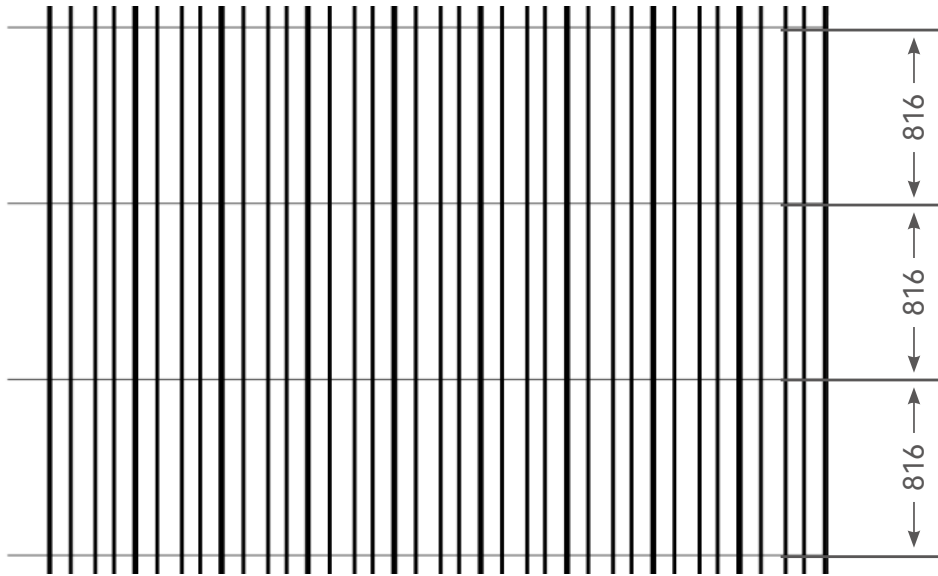

FIGURE 18

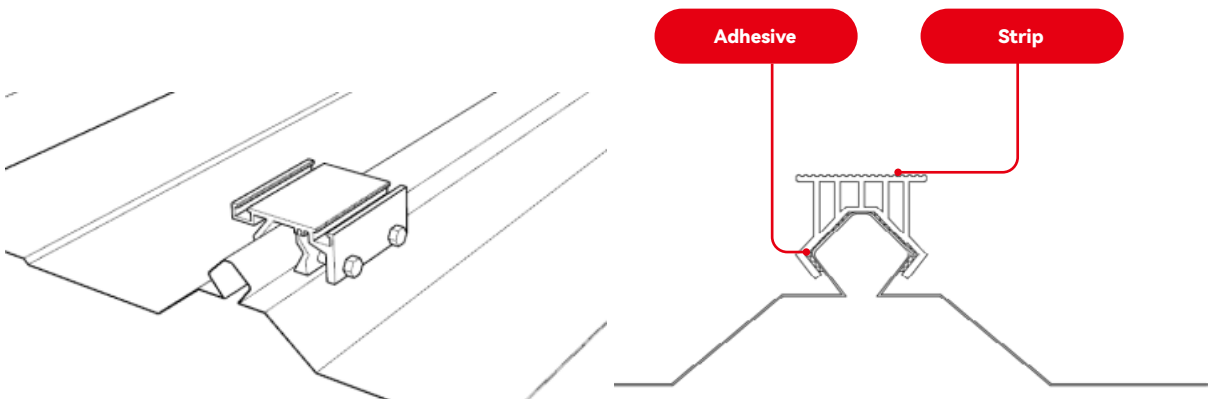

FIGURE 19

FIGURE 20

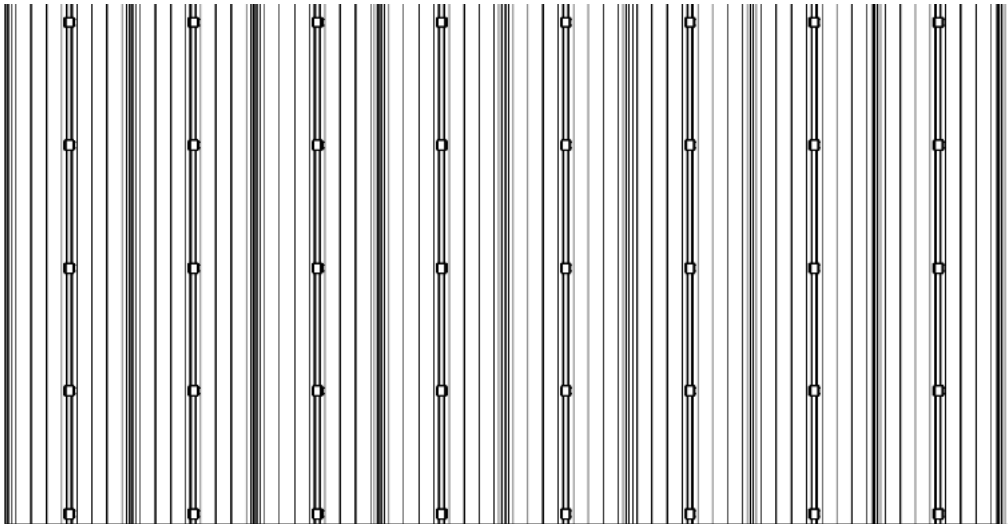

FIGURE 21

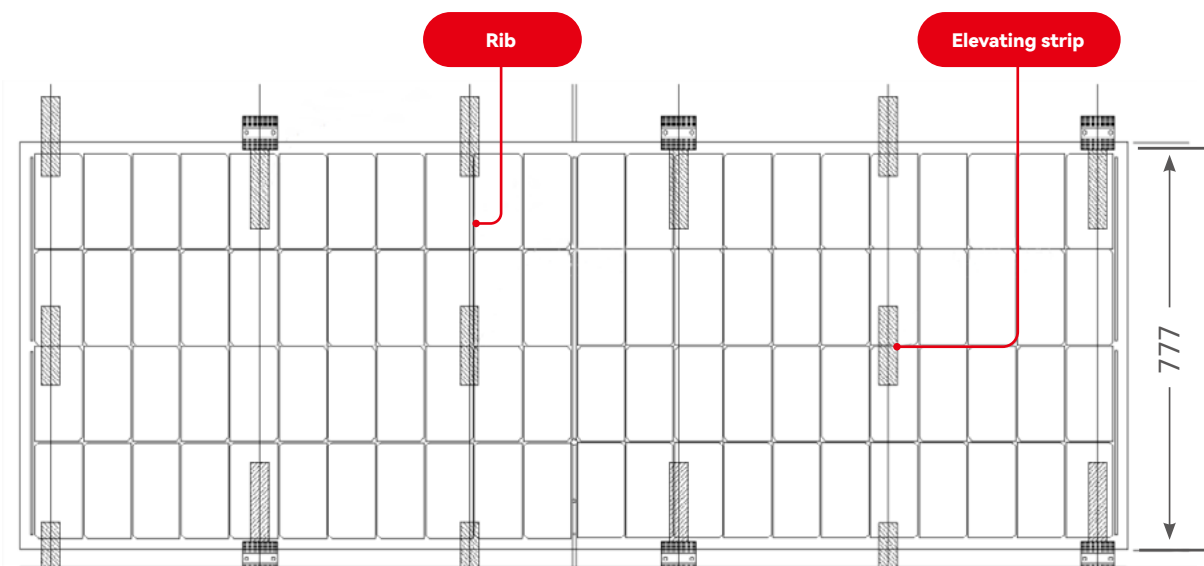

FIGURE 22

- ③ Using elevating strips on the diamond-shaped rib (Figure 21), with one end of the strips pressed against the side of the clamp and the position of each strip as shown in the diagram (Figure 22).
- ④ Installation of the remaining products in the same form as the installation of the angle-chip type colour steel tile roofing.

Standing seam colour metal roofing installation:

The standing seam colour metal roof consists entirely of semi-circular ribs (Figure 23)

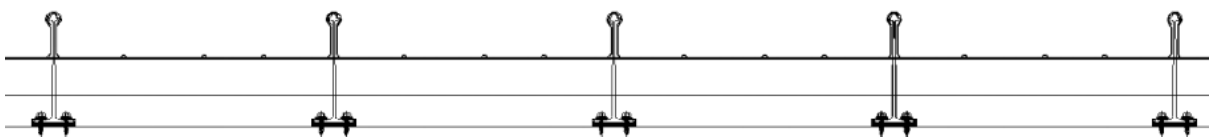

FIGURE 23

① First determine the installation position of the clamps, then carry out the snapline as the installation axis, the centre line of each row of clamps should be $816\pm 2\text{mm}$ apart, note that the snapline is at an angle of 90 degrees to the rib of the colour steel tile (Figure 24)

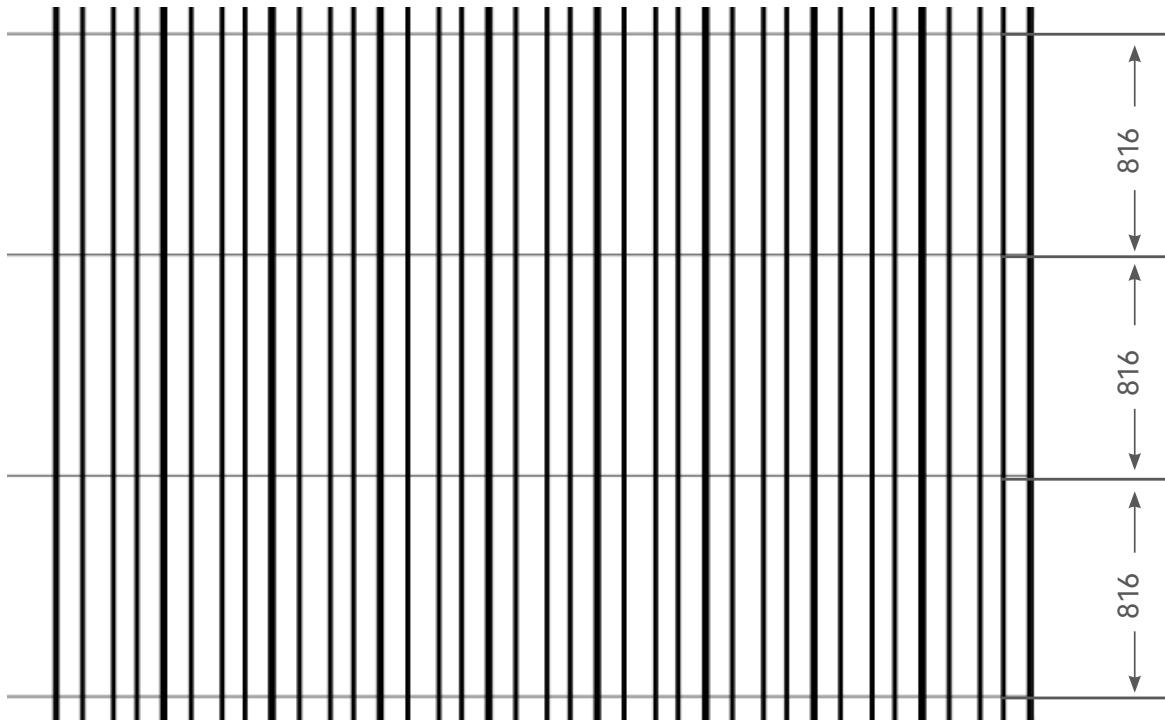

FIGURE 24

② Install the clamp on the round rib according to the position of the snapline, and use the hexagonal bolt to lock the clamp for installation (Figure 25), the overall installation result is as follows (Figure 26)

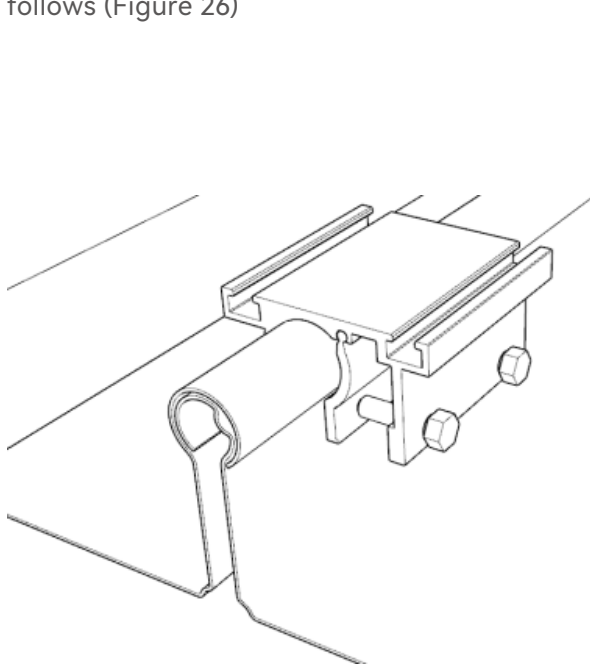

FIGURE 25

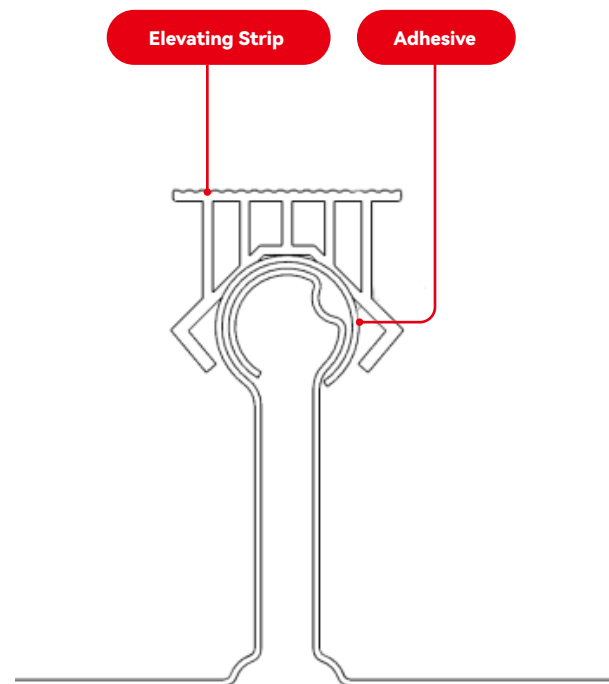

FIGURE 26

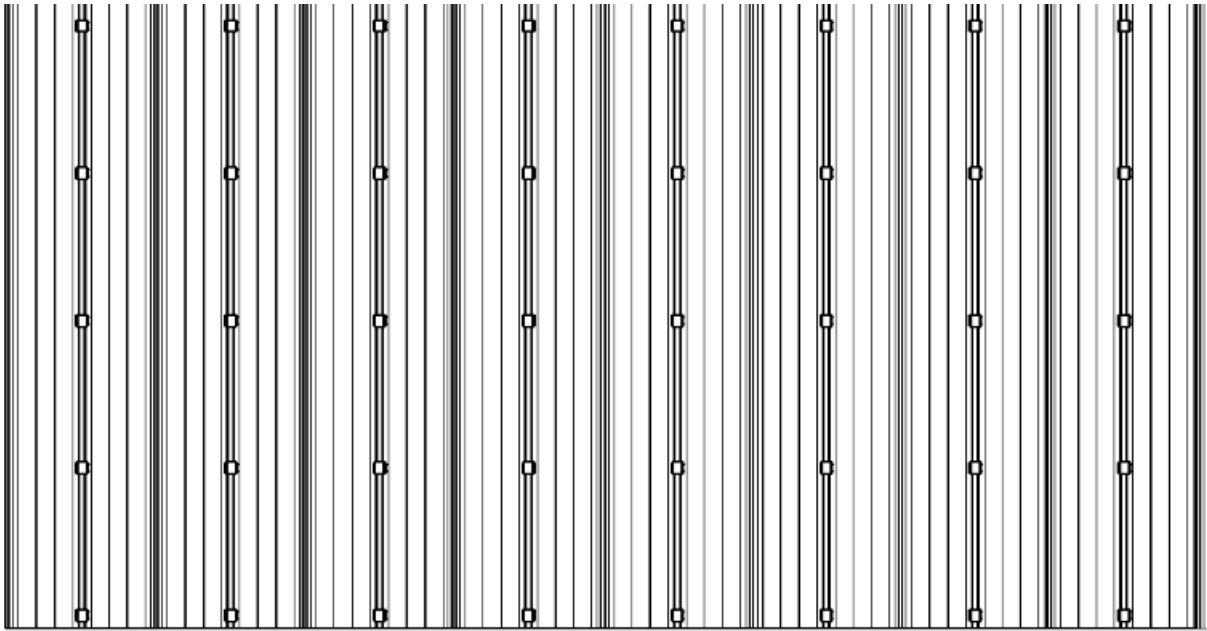

FIGURE 27

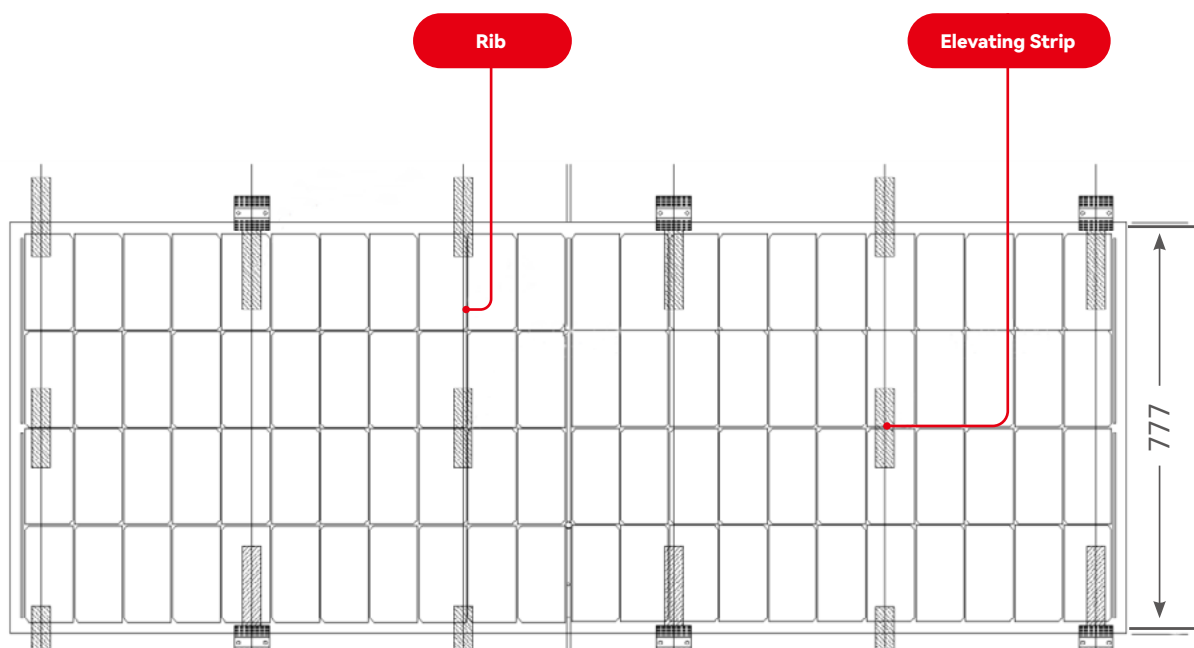

FIGURE 28

- ③ Use elevating strips on the round rib (Figure 27), one end of the strip is placed close to the side of the clamp, and in the non-clamp position the strip is placed in the middle of the 2 products. The position of each strip in the middle of the product is shown in the diagram (Figure 28)
- ④ Installation of the remaining products in the same form as the installation of the angle-chip type colour steel tile roofing;

Low standing seam colour metal roofing installation:

The low standing seam (single lock) colour metal roof consists entirely of square ribs (Figure 29)

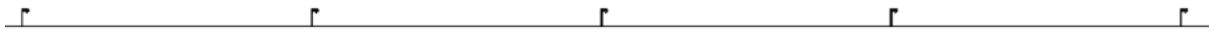
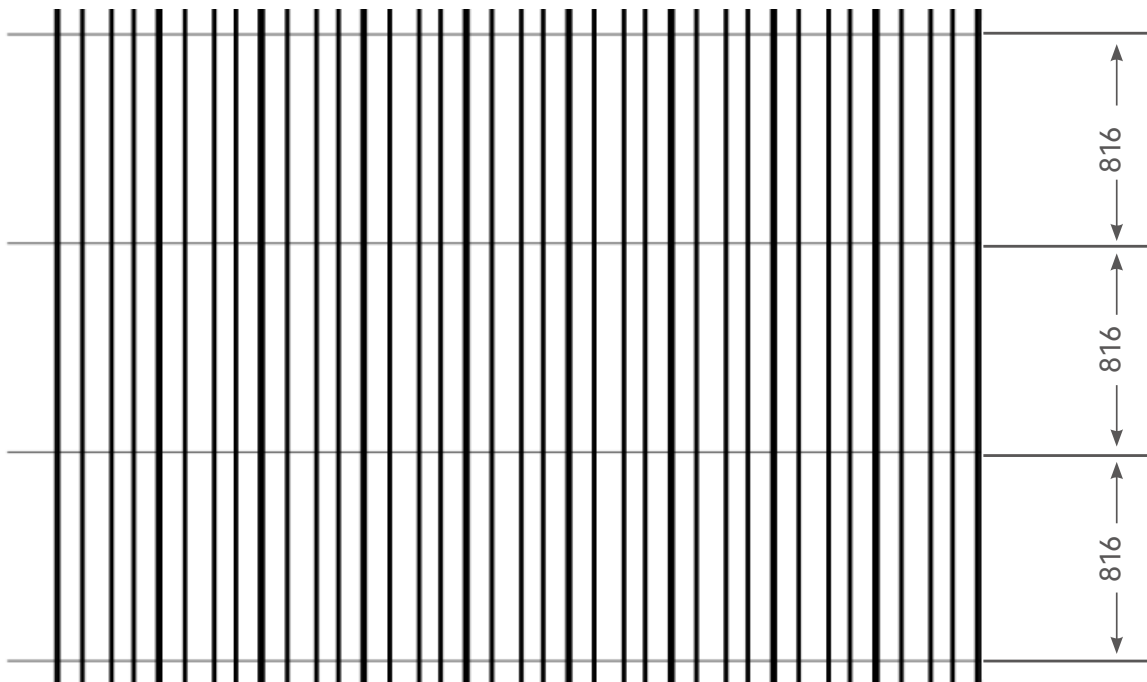

FIGURE 29

① First determine the installation position of the clamps, then carry out the snapline as the installation axis, the centre line of each row of clamps should be $816 \pm 2\text{mm}$ apart, note that the snapline is at an angle of 90 degrees to the rib of the colour steel tile (Figure 30)



② Install the clamp on the square rib according to the position of the snapline, and use the external hexagonal bolt to lock the clamp for installation (Figure 31), the overall installation result is as follows (Figure 32)

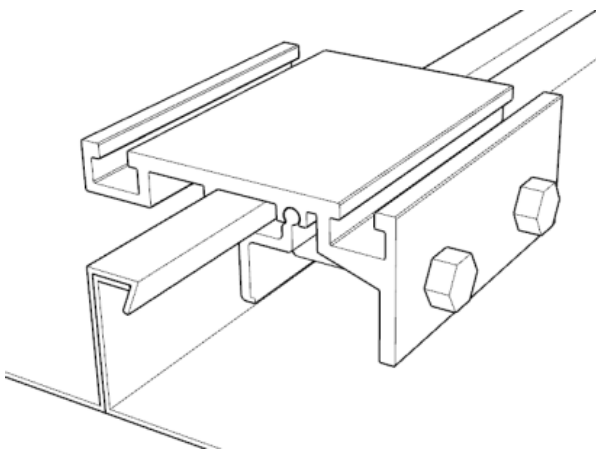

FIGURE 31

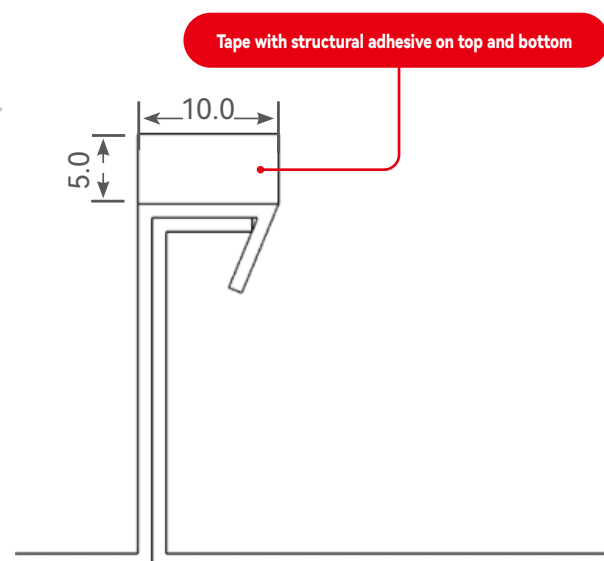

FIGURE 32

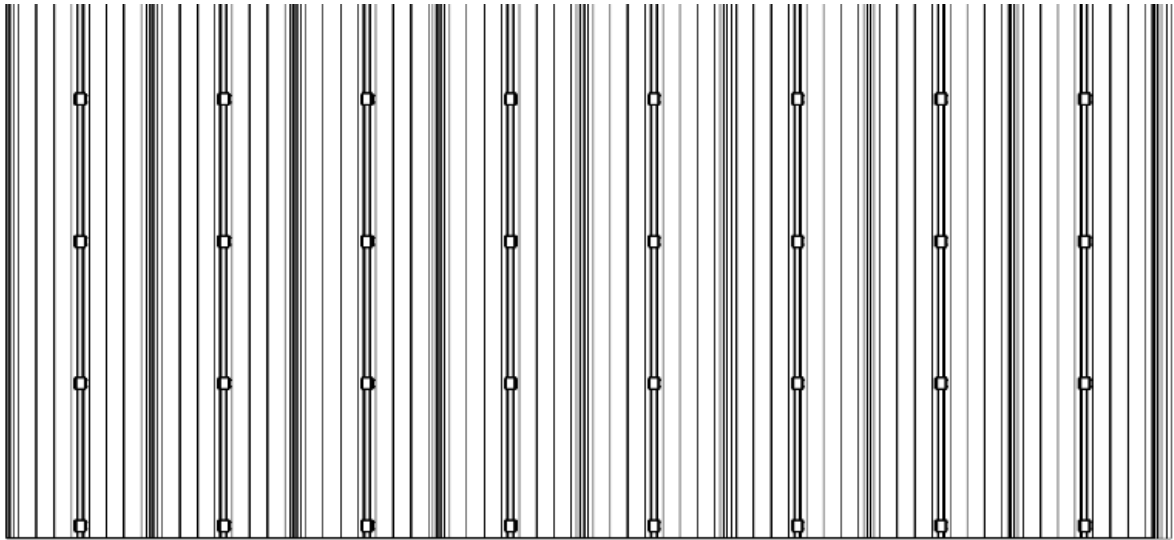

FIGURE 33

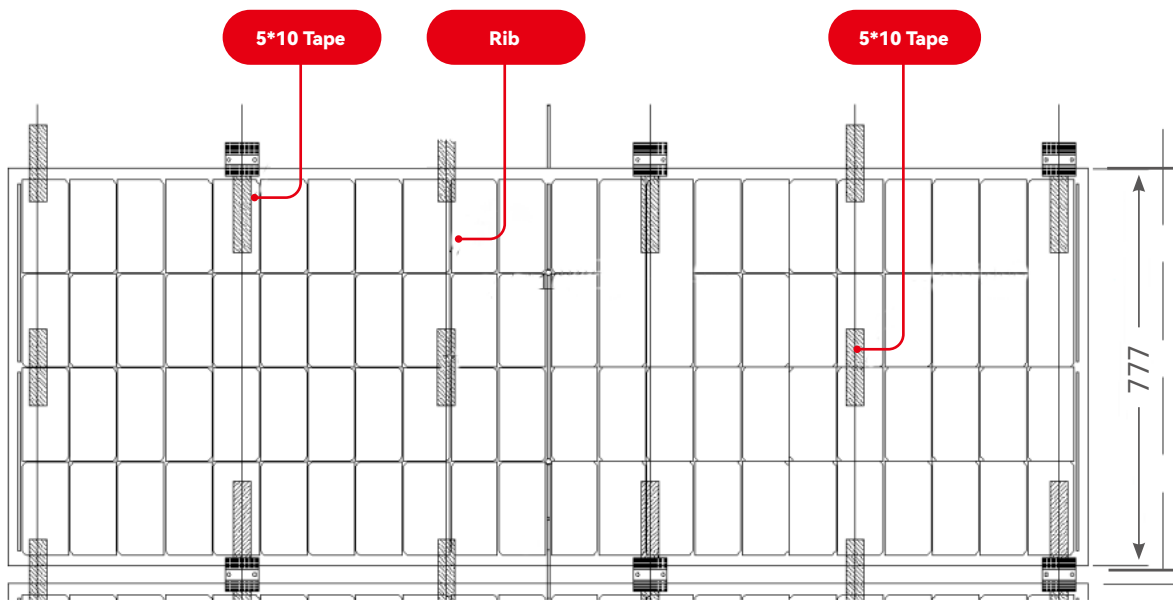

FIGURE 34

- ③ Use structural adhesive plus tape on the square rib (Figure 33), square rib position using 5mm thick, 10mm wide tape, tape placed on both sides of the clamps where there are clamps, tape placed in the middle of 2 products and in the middle of the product without clamps (Figure 34)
- ④ Installation of the remaining products in the same form as the installation of the angle-chip type colour steel tile roofing;

Metal Roofing Installation:

- Klip-Lok 700 colour steel tile rib is made of Square rib (Figure 35);



FIGURE 35

① Mark the position of Galaxy and the clamps with snapline, the centre line of each row of the clamp is $816 \pm 2\text{mm}$ apart, note that the snapline is perpendicular to the ridges of Klip-lok roofsheet(Figure 36)

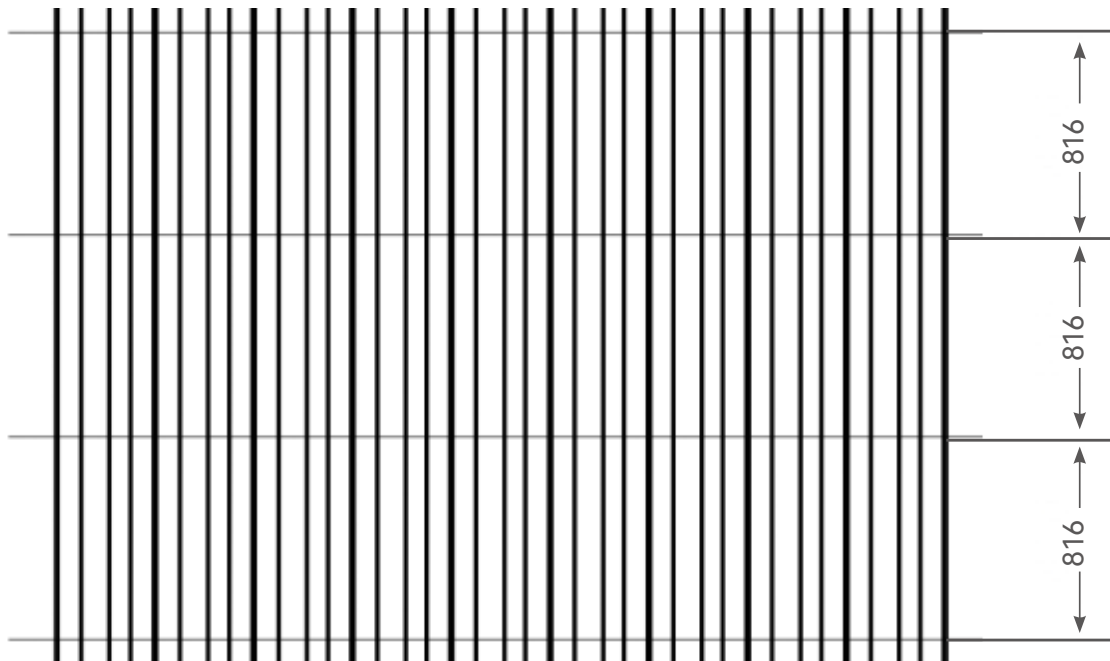

FIGURE 36

② Install the clamp base on the square rib according to the position of the snapline, and use the external hexagonal bolt to lock the clamp base for installation (Figure 37)as shown below(Figure 38);

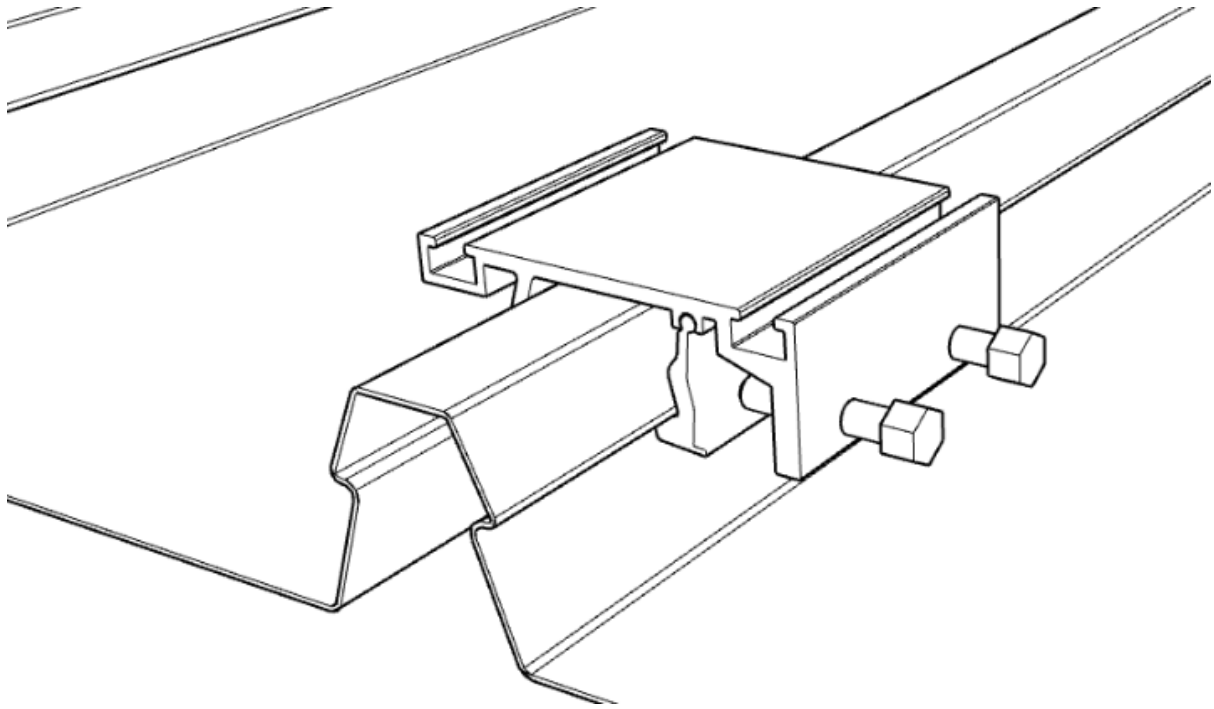

FIGURE 37

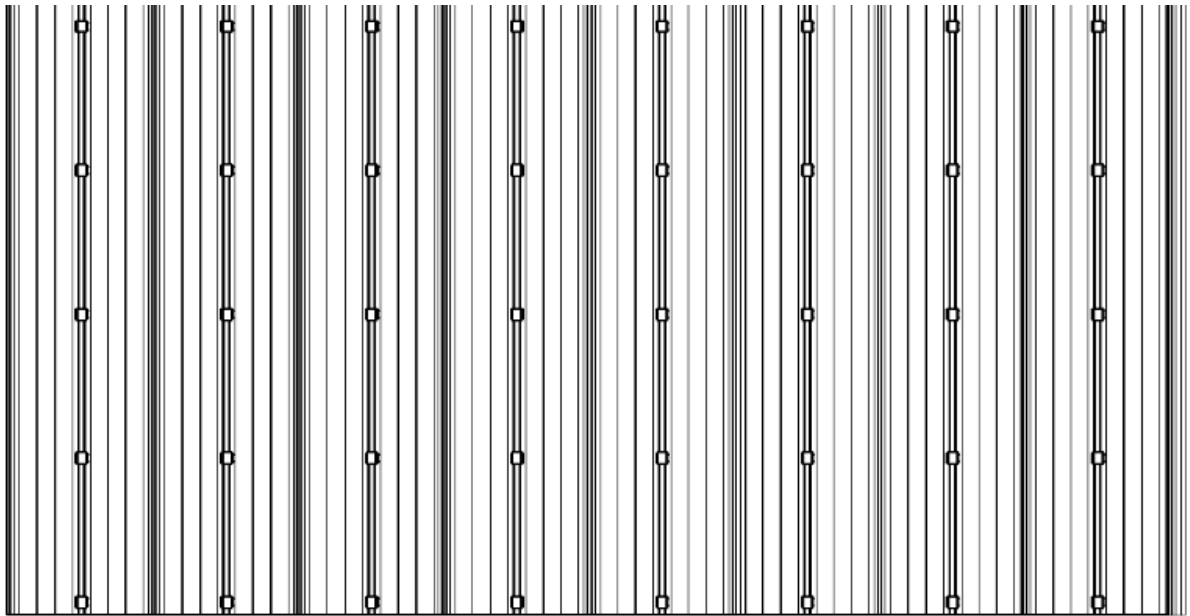

FIGURE 38

③ Install tape and structural adhesive on the non-bracketed rib for structural gluing. The width of the tape is 8mm, with a height of 8mm. The surface of the structural adhesive should be higher than the surface of the tape to ensure that the back of the product can fully contact with the adhesive (Figure 39). The overall length is 200mm. Install tape on both sides of the bracket (Figure 40). See (Figure 41) for details of the arrangement;

Note: For Galaxy Plus, install tape and clamp strips on the edge lines. In non-bracket positions, install tape and clamp strips in the middle. In bracket positions, install tape on both sides.

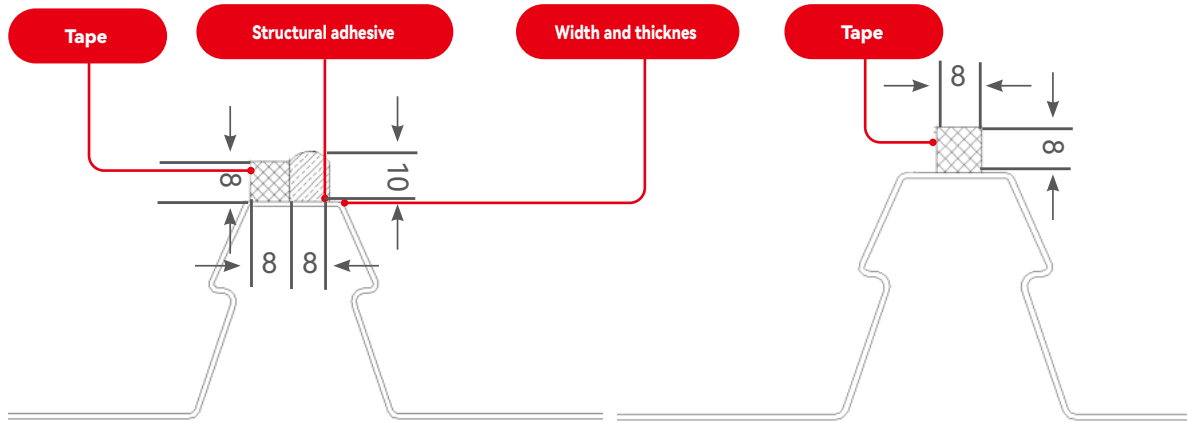

FIGURE 39

FIGURE 40

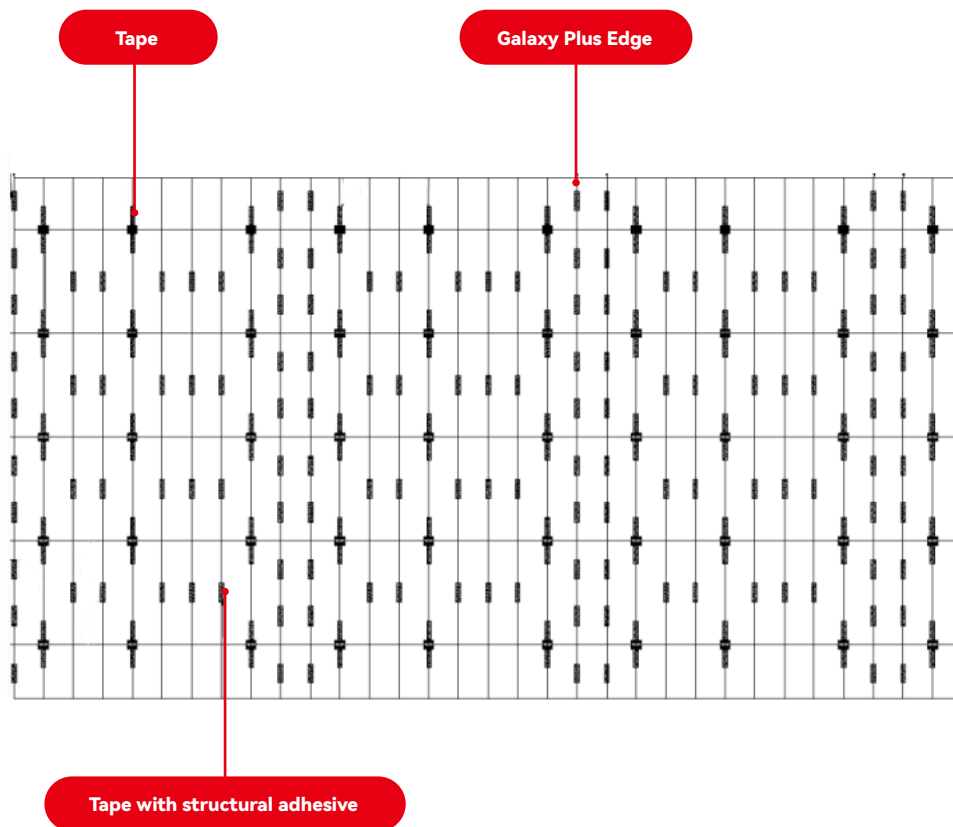

FIGURE 41

④ Installation of the remaining products in the same form as the installation of the angle-chip type colour steel tile roofing;

5.8 PRINCIPLES FOR THE ARRANGEMENT OF PRODUCTS ON DIFFERENT METAL ROOFINGS

- Each Galaxy product should be fitted with a minimum of 3 clamps in the direction of the two long sides
- When the number of clamps is 4, the mounting position of the clamps on the product should be adjusted appropriately
- The overhang dimension B should be equal at both ends of the product and should not be greater than 200 mm (Figure 42)
- The installation of Galaxy products is suitable for metal roofs with wave rib adjacent spacing not greater than 450mm (Figure 43). If Galaxy product is to be installed on roofs with wave rib spacing dimensions greater than 450mm, a load test should be carried out first and only when the requirements are met.

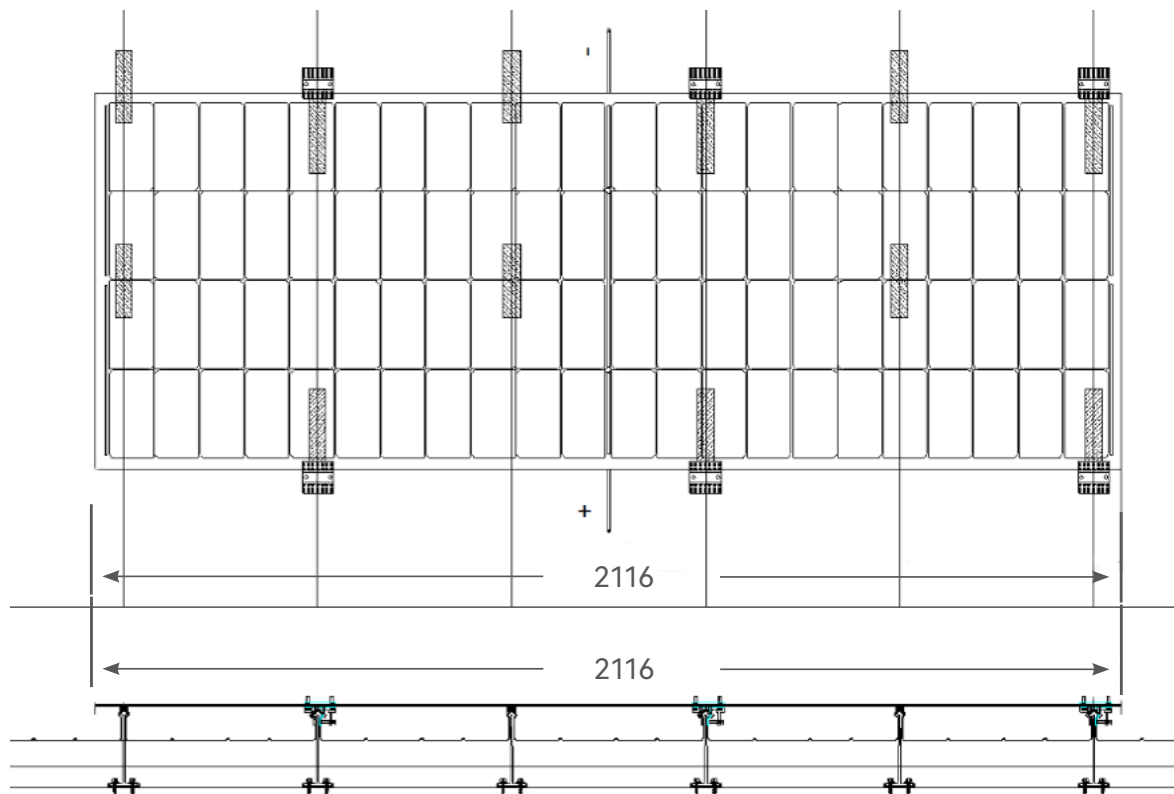

FIGURE 42

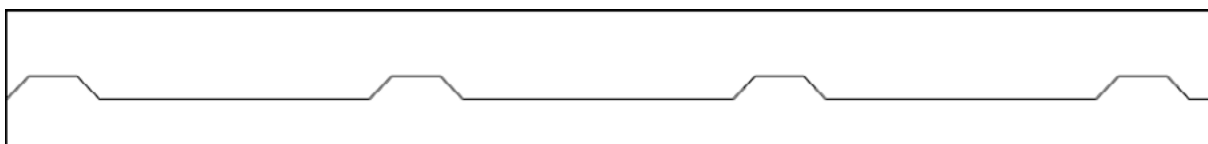

FIGURE 43

6

ELECTRICAL INSTALLATION

6.1 ELECTRICAL PERFORMANCE

- The nominal values of electrical performance parameters such as I_{sc} , V_{oc} and P_{max} of Galaxy Plus products have an error of $\pm 3\%$ from those under standard test conditions. Standard test conditions for Galaxy Plus products: irradiance 1000 W/m^2 , cell temperature 25° C , atmospheric mass AM 1.5.
- When Galaxy Plus products are connected in series, the total voltage is the sum of voltage of every single Galaxy Plus products in the string, and when Galaxy Plus products are connected in parallel, the final current is the sum of the current of every string of Galaxy Plus products, as shown in Figure 44. Galaxy Plus products of different electrical performance models should not be connected in one string.

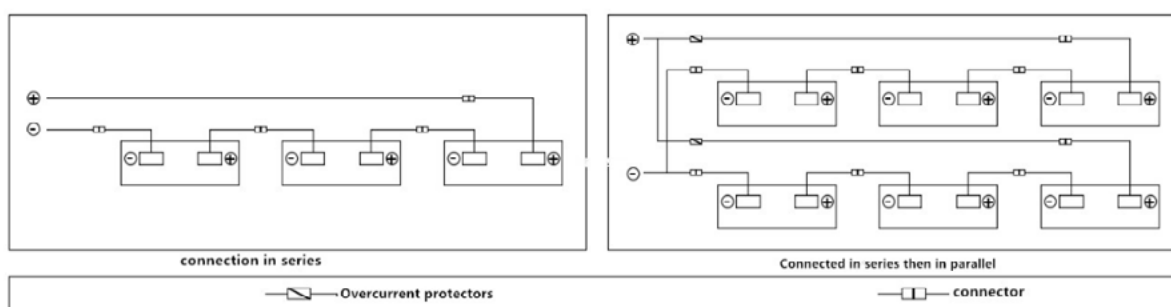

FIGURE 44
SERIES-PARALLEL ELECTRICAL DIAGRAM

- The maximum number of single strings of Galaxy Plus products that can be connected in series must be calculated in accordance with the requirements of local electrical requirements and regulations. and the value of its open-circuit voltage at the lowest expected local temperature conditions must not exceed the maximum system voltage value specified for Galaxy Plus products (maximum system voltage for the products is DC1000V/DC1500V - the actual system voltage is designed according to the selection of the product models and inverters) and other values required for DC electrical components.

- The open circuit voltage correction factor can be calculated with the following formula:

$$CV_{oc} = 1 - \beta V_{oc} \times (25 - T)$$

where T is the minimum ambient temperature expected at the system installation location and β ($\%/^\circ \text{ C}$) is the temperature coefficient of the open circuit voltage of selected Galaxy Plus product (refer to the corresponding Galaxy Plus product parameter table).

- If a reverse current exceeding the maximum fuse current of the Galaxy Plus product may pass through the Galaxy Plus product, an overcurrent protection device of the same size must be used to protect the product. If the number of parallel connections is more than or equal to 2 strings, there must be an overcurrent protection device on each string of the products, as shown in Figure 44.

6.2 CABLE AND CONNECTING WIRES

- Galaxy Plus products shall be connected by using IP67-rated junction boxes, which shall provide safe protection for the conductors and their corresponding connections, and accessible protection for non-insulated live parts. The junction box consists of a connected cable and IP67-rated connectors to facilitate a series connection between Galaxy Plus products. A single product has two separate wires connected to two separate junction boxes, one positive and one negative. Two Galaxy Plus products can be connected in series by inserting the positive connector into the socket of the negative connector of the adjacent product.
- Use dedicated solar cables and appropriate connectors (wires should be encased in age-resistant conduit or, if exposed to air, should be age-resistant themselves) and ensure that the cables are electrically and mechanically sound, in accordance with local fire, building and electrical codes. Installers should only use single-core solar cables, 2.5-16mm² (5-14 AWG), 90° C rated, with appropriate insulation to withstand the maximum possible system open circuit voltage (as approved by EN 50618). Appropriate wire sizes need to be selected to minimize voltage drop. All wiring and electrical connections comply with the requirements of the appropriate National Electrical Code or standard. Avoid mechanical damage to the cable or Galaxy Plus products when the cable is secured to the bracket. Do not press the cable with force. The cable shall be secured to the bracket by specially designed aging-resistant cable ties and wire clips. Although the cable is resistant to aging and water, it should be protected from direct sunlight and rain. The minimum bending radius of the cable should be 43mm.



FIGURE 45 MINIMUM BENDING RADIUS OF THE CABLE

6.3 CONNECTOR

- Please keep the connector dry and clean, and make sure that the nut of the connector is tightened before connecting. Do not connect the connector when it is wet, dirty or in other unfavorable conditions. If the connector is not connected properly to the other polarity, the connector is not waterproof. It is necessary to connect or take appropriate measures to avoid the infiltration of water vapour and dust as soon as possible after the module is mechanically installed on the roof. Avoid having connectors exposed to direct sunlight and immersed in water. Avoid having connectors falling on the ground or the roof. Incorrect connections may produce arcing and electric shock. Make sure all electrical connections are secure. Make sure that all connectors with locking are fully connected.
- It is not recommended that connectors of different models be connected and used together.

6.4 BYPASS DIODE

● The cell strings within a solar module are protected by bypass diodes in parallel and encapsulated in a junction box. When a hot spot phenomenon occurs locally in a module, the diode will activate so that string current no longer flows from the hot spot cells, thus limiting module heating and performance loss. Note that the bypass diode is not an overcurrent protection device. Contact the installer or system maintainer when a diode failure is detected or suspected. Do not attempt to open the module's junction box by yourself.

6.5 ELECTRICAL REQUIREMENTS FOR THE INSTALLATION OF GALAXY PLUS PRODUCTS

1. Inspection before installation

- ① No visible defects.
- ② Models and specifications should meet the requirements of the design drawings.
- ③ Accessories and spare parts are available;

2. Preparation of main tools

- ① Multimeter: For measuring the open-circuit voltage of Galaxy Plus products.
- ② Angle measuring instrument, level, etc.: measuring the installation angle of the Galaxy Plus product array.
- ③ Installation tools and spare parts are covered in Section 4.

6.6 MATERIAL PREPARATION

Please check whether the type and quantity of the arriving material is correct against the material list in the configuration sheet.

1. Galaxy Plus Products Electrical Wiring Requirements

- ① Wiring with clear, unambiguous and easily understood wire number identification.
- ② Jumper cable diameter must exceed the original Galaxy Plus product cable diameter, and flame retardant and insulation performance should also be no less than that of Galaxy Plus product cable.
- ③ Galaxy Plus products should be connected to each other in the shortest cable run possible.
- ④ When Galaxy Plus products require long straddle connections, try to minimize the difference in the total length of each set of string-connected cables.
- ⑤ The wiring terminals should be in good contact. When connecting each part of the Galaxy Plus product in series, it is best to test once each section is completed with a multimeter-to-string connectivity.

2. Electrical wiring method of Galaxy Plus products

- ① Wiring in accordance with the wiring in the electrical schematic.
- ② For products connected in series, the "+" pole of one product is connected to the "-" pole of another product. Extension cables are required if the connection of products between different rows is needed.
- ③ Please use extension cables that are for solar applications specifically. (Figure 46)



FIGURE 46
PRODUCT JUMPER CONNECTION OPERATION INSTRUCTIONS (FRONT VIEW)

- ④ When a group of series connections are connected as shown in the drawing, the remaining group of "+" and "-" pole terminals are connected to the combiner connector or combiner box.
- ⑤ Parallel connection of all accessory strings is done at the combiner connector or combiner box.

Note: This document only describes the wiring requirements and wiring principles. Since the roof of each site may not be the same, it is not possible to make a uniform wiring process for each project here. Wiring can be done later in accordance with the product installation layout drawings in each project.

6.7 COMBINER BOX INSTALLATION REQUIREMENTS

- ① Connect the combiner kit to the product array according to the electrical schematic.
- ② The plug should be properly inserted and securely connected for a firm fit.
- ③ The combiner kit can be fixed on the bracket, the alignment is neat and easy to maintain.
- ④ The connection of the cable should avoid cable stress and friction due to wind-blown vibration and damage to the outer skin of the cable.
- ⑤ After the terminals of the combiner kit are connected, use the same cable clamps as the terminals of the product to clamp up the ends of the terminals.

7

ELECTRICAL CONSTRUCTION PROCESS

7.1 ELECTRICAL CONSTRUCTION PROCESS

● Operating conditions

- ① Assembly of product array is completed.
- ② Installation of inverter and distribution box is completed.

● Preparation of main tools

- ① Impact drill: For drilling holes in the installation position of PVC and other conduit clips.
- ② Crimper: For on-site DC cable splice plug production.
- ③ Multimeter, megohmmeter: For cable conduction and insulation testing.
- ④ Wire stripping pliers: For cable stripping.

● Main Materials

- ① DC cables for photovoltaics.
- ② AC cables.
- ③ Cable DC connectors use the same type of the product or a compatible one which satisfy local standards and requirements.

● Installation Engineering Process

- ① Determine the cable run and AC/DC conduit requirement after on-site measurement.
- ② Conduit is required for cables between the array and the inverter. Conduit is required for cables between the inverter and the distribution box, and between the distribution box and the household electricity box.

● Conduit laying requirements

- ① Follow local electrical standards and regulations when designing and laying the conduits, requirements of local standards and regulations prevail if contradictions are found.
- ② When laying electrical conduits on the wall, they should be laid in the corners of the wall, in the same direction as rainfall pipes and air-conditioning pipes.
- ③ It is advisable to avoid the crossover of AC and DC directions in the piping between equipment.

● Cable laying

Requirements for cable laying:

- ① When wiring each system, the type of conductor, voltage level, etc. are inspected according to the provisions of the current national standards.
- ② Remove water and debris from the conduit or wire channel before threading.
- ③ When using the crimping method to connect the wire, the specifications of the terminal copper sleeve crimp should be consistent with the cross-section of the cable core.

- ④ AC and DC cables should be run in different conduits to ensure safety.
- ⑤ After the cable is installed, the joints should be glued and sealed to prevent water from seeping into the conduit. The opening of exposed conduits should be plugged with a soft cloth to avoid the entry of foreign objects.
- ⑥ Cable bending radius $\geq 6D$.
- ⑦ Wiring through conduits to avoid high temperature heat generating objects as much as possible.
- ⑧ Conduits need to be secured by conduit clips.
- ⑨ The AC and DC cables connected to the inverter and distribution box should be marked with the cable number at both ends.

DC side cable connector installation.

- ① Arrange cable connectors and pins according to their intended polarity.
 - ② Strip the DC PV cable by using wire strippers according to the length of the copper core pins.
 - ③ Insert the DC PV cable into the pins, and crimp the pins.
 - ④ Insert the pins into the male and female connectors and fasten them with the special screwdriver.
- Plug in the male and female cable connectors and test the tightness of the connection.

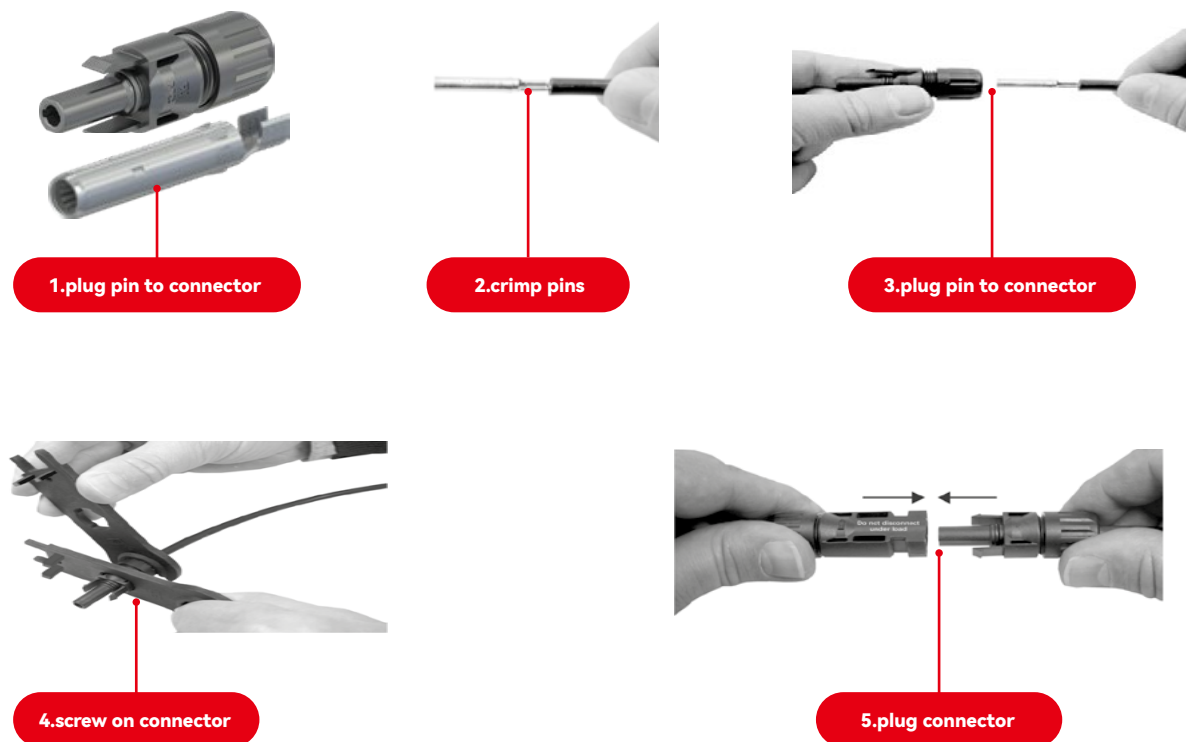

FIGURE 47 CABLE CONNECTOR PRODUCTION METHOD

● Sub-project requirements

- ① PVC flame-retardant rigid plastic pipe and its attached oxygen index should be 27% or more.
- ② Insulation of the cables should be tested before being threaded into conduits.
- ③ The minimum allowable bending radius of the cable laid through the pipe is six times of cable diameter.
- ④ The conduit clip spacing of exposed conduits should be:
 - a. $\Phi 20$ pipes are laid openly along the wall with a maximum distance of 1.5m between pipe clips;
 - $\Phi 25$ pipes are laid openly along the wall with a maximum distance of 2m between pipe clips.
 - b. Allowable value of deviation for the laying of open piping.

Straightness	<1.5mm/m
Verticality	<1.5mm/m

- ⑤ Cables from different circuits, different voltages or AC and DC cables, should not be worn in the same conduit.
- ⑥ There shall be no joints in the wires in the conduits.
- ⑦ Connect the plugs tightly.

8

OPERATION AND MAINTENANCE

Products require regular inspection and maintenance, especially during the warranty period. To ensure optimum performance, GOODWE recommends the following measures:

8.1 VISUAL INSPECTION:

Visual inspection of the product for damage or other conspicuous features, focusing on the following:

- ① Whether the glass of the product is broken.
- ② Whether corrosion has occurred near the fingers of cell, which is caused by water vapour entering the product due to breakage of the surface encapsulation material during installation or transport.
- ③ Whether the back plate of the product has broken.
- ④ Whether the product has signs of aging, including animal damage, weathering, corrosion and whether the connection of connectors is tight and whether the products are well grounded.
- ⑤ The surface of the product should not be touched with sharp objects;
- ⑥ The products should not be shaded;
- ⑦ Whether there is any loosening or damage to the fixing of the product to the purlin or the base. Please make timely adjustments or repair if any damage is identified.

8.2 CLEANING

- ① Dust and dirt on the surface of the product will reduce the power output. GOODWE recommends using a sponge or soft cloth containing water to wipe the glass surface and strictly forbids the use of cleaning agents containing acids or alkalis to clean the product.
- ② Please remove snow and ice without force. Please use a soft broom in order not to damage the protective layer of the product.
- ③ Do not use rough and sharp tools to clean products.
- ④ To reduce potential electric shock or burns, GOODWE recommends cleaning the product in the early morning or late evening when there are low irradiation levels and low temperatures.
- ⑤ Do not clean products with broken glass or back plates, exposed wires or broken features to avoid the risk of electric shock.
- ⑥ Always wear rubber gloves whilst servicing, washing, or cleaning the modules and pay attention to the connection of cables and electrics.

8.3 CONNECTORS AND CABLE CONNECTIONS

It is recommended to carry out a preventative inspection every 6 months

- ① Check whether the junction box sealant has cracks or gaps.
- ② Check whether the connectors are sealed and the cable connections are secure.

9

CAUTIONS

The following maintenance measures are recommended to ensure that the products achieve optimum performance and maximum system power generation.

1.Product appearance inspection focuses on the following:

- ① Whether the product is damaged or not.
- ② Whether sharp objects are touching the surface of the product.
- ③ Whether the product is shaded by obstacles and foreign objects, newly grown trees, newly erected poles, etc.
- ④ Whether there is corrosion near the cell grid wire.

2.Product cleaning. The accumulation of dust or dirt on the surface of the product will reduce the power output. It should be cleaned regularly to keep the surface clean, and generally should be cleaned at least once a month. Cleaning frequency should be adjusted depending on the local environment.

Please note the following when cleaning photovoltaic products:

- ① Make sure the products and cables are not broken before cleaning the product.

- ② First rinse the product with clean water, and then wipe the water stains dry with a soft cloth, it is strictly prohibited to use corrosive solvents to clean or wipe PV products with hard objects.
- ③ PV products should be cleaned at irradiance below 200W/m², preferably when there is no sunlight or in the morning and evening.
- ④ It is strictly forbidden to wash PV products during strong wind (wind force greater than 4), heavy rain or heavy snow.

Attention: Do not walk, stand or sit on the product for product cleaning.

3.Product connector and cable inspection. It is recommended to inspect them every six months in a preventive manner.

- ① Inspect PV products for signs of aging. This includes possible rodent damage, weather aging, and that all connectors are tightly connected and free of corrosion.
- ② Do not disassemble the product by yourself if it is damaged, please inform the professional to handle it.

4.All electrical installations must comply with electrical installation standards and be completed by an electrical professional. Ensure that all input and output switches are off.

5.Do not connect the DC cable to the inverter AC output socket, and do not short-circuit or ground the output circuit.

6.The cable route between the DC input and the inverter should be as short as possible.

7.Different colour cables should be selected to differentiate the connection process. The positive terminal is connected to the red cable and the negative terminal is connected to the blue cable.





8.To ensure the balance between the product strings, the selected DC cables should have the same cross-sectional area.

9.Make sure to cover the product with an opaque material or disconnect the DC side circuit breaker before making electrical connections. The product array will generate dangerous voltages when exposed to sunlight.

APPENDIX

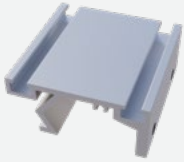
1.BOM List

Angle ridge type clamp kit (Customized Standard)

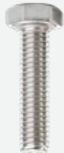
 <p>main clamp</p>	<p>Function Assemble to form a fixture</p>
<p>Quantity 1</p>	
 <p>clamp component</p>	<p>Function Assemble to form a fixture</p>
<p>Quantity 1</p>	
 <p>clamp coverplate</p>	<p>Function Assemble to form a fixture</p>
<p>Quantity 1</p>	
 <p>M6 bolt</p>	<p>Function Assemble to form a fixture</p>
<p>Quantity 2</p>	
 <p>M6 screw</p>	<p>Function Assemble to form a fixture</p>
<p>Quantity 2</p>	



Function Placed on diamond shaped peaks to support panels
Quantity 232mm



Function Placed in the slot of the fixture to fix panels
Quantity 2

Standing seam type clamp kit (Customized Standard)



Function Assemble to form a fixture
Quantity 1



Function Assemble to form a fixture
Quantity 1



Function Assemble to form a fixture
Quantity 1



Function Assemble to form a fixture
Quantity 2



Function Assemble to form a fixture
Quantity 2



Function Placed on diamond shaped peaks to support panels
Quantity 232mm



Function Placed in the slot of the fixture to fix panels
Quantity 2

Low standing seam type clamp kit (Customized Standard)



Function Assemble to form a fixture
Quantity 1



clamp component

Function Assemble to form a fixture

Quantity 1



clamp coverplate

Function Assemble to form a fixture

Quantity 1



M6 bolt

Function Assemble to form a fixture

Quantity 2

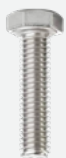

M6 screw

Function Assemble to form a fixture

Quantity 2



clamp strip

Function Placed in the slot of the fixture to fix panels

Quantity 2

Clamp kit (Overseas) (Customized Standard)



Function Assemble to form a fixture

Quantity 1

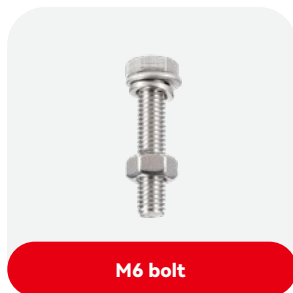

Function Assemble to form a fixture

Quantity 2

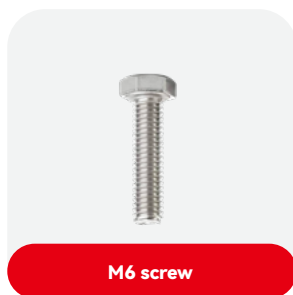

Function Assemble to form a fixture

Quantity 2



Function Assemble to form a fixture

Quantity 2